

## VR Series, 2 x 3/2, 5/2 or 5/3 Valve Islands

- Vertical or Horizontal 24V DC Multipole
- Industrial Ethernet, Fieldbus and IO-Link
- 10/15mm Valve Island
- Modular system offering a wide range of configuration options
- LED indicator of solenoid function
- No restriction in installation
- Up to 24 solenoids
- Easy to replace valves and fittings
- IP40 or IP65 protection
- To configure and order a Valve Island visit - <https://www.norgren.com/en/support/configurators/valve-island-configurators>

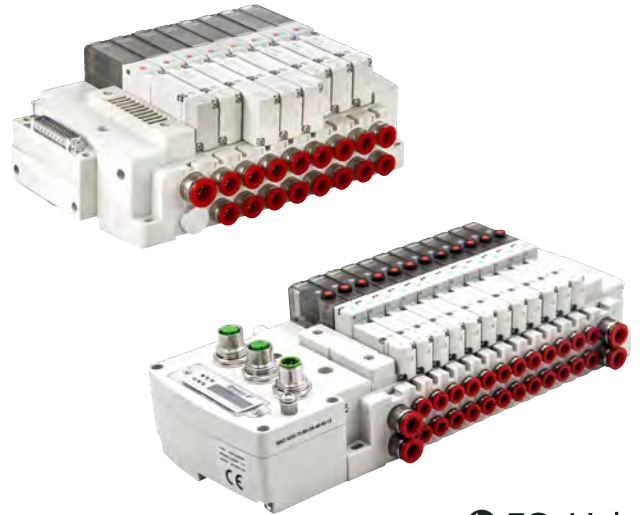

 IO-Link

### Technical features

#### Medium:

Compressed air, filtered to 40 µm, lubricated or non-lubricated

#### Operation:

Dynamic softseal spool valve, solenoid pilot operated

#### Flow:

Function	l/min	Cv	Kv
VR10			
5/2	220	0.22	0.20
5/3	270	0.27	0.24
2 x 3/2	220	0.22	0.20

#### VR15

Function	l/min	Cv	Kv
5/2	520	0.53	0.47
5/3	590	0.60	0.54
2 x 3/2	460	0.47	0.42

#### Mounting:

Sub-base

Ports 1, 3 & 5 (P,E):

VR10: PIF 8 mm, 5/16"

VR15: PIF 10 mm, 3/8"

Ports 2 & 4 (A,B):

VR10: PIF 4 mm, 6 mm, 5/32", 1/4"

VR15: PIF 4 mm, 6 mm, 8 mm, 5/32", 1/4", 5/16"

#### Operating pressure:

Maximum pressure 7 bar (101 psi). Details of minimum and maximum pilot pressure see overleaf

#### Materials:

Body: ZnDC and ADC  
Spool: Aluminium  
Seal: NBR  
Sub-base: PA66

#### Media/Ambient temperature:

-5 ... +50 °C (+23 ... 122 °F)  
Air supply must be dry enough to avoid ice formation at temperatures below +2 °C (+35 °F).

### Electrical details for solenoid operators

Supply voltage*:	12 V d.c. & 24 V d.c.
Power consumption*:	12 V d.c. & 24 V d.c. 0.45W (Energy saving type)
Manual override:	Push only
Rating:	100 % E.D.
Indication:	LED red/green
Surge suppression:	surge protecting circuit is equipped
Protection class:	IP40 or IP65

\*12 V d.c. valves only for Multipole and CANopen

## Technical data valve

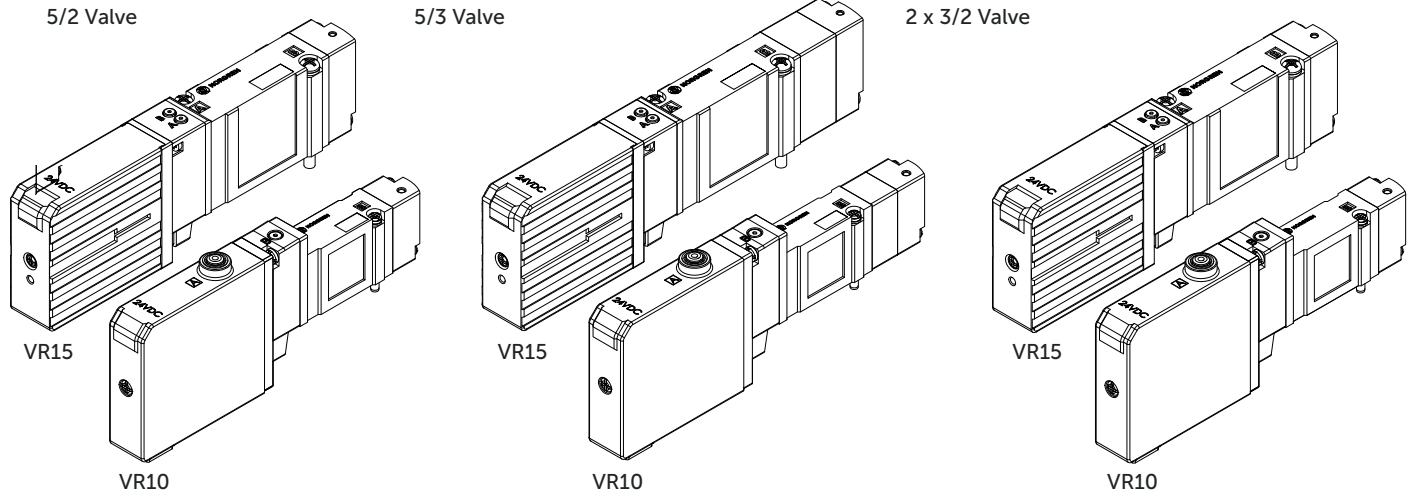

### 5/2 Single and double solenoid actuated valves

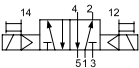
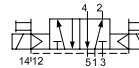
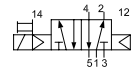
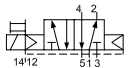
Symbol	Series	Function	Actuation	Pilot Supply	Pilot Pressure (bar / psi)	Operating Pressure (bar / psi)	Manual Override	Voltage *1)	Weight (kg / lbs)	Model PNP
	VR10	5/2	Sol./Sol.	Internal	2~7 / 29~101	2~7 / 29~101	Push only	24 V d.c.	0.069 / 0.1518	VR10S511BV313A
	VR15	5/2	Sol./Sol.	Internal	2~7 / 29~101	2~7 / 29~101	Push only	24 V d.c.	0.093 / 0.2046	VR15S511BV313A
	VR10	5/2	Sol./Sol.	Internal	2~7 / 29~101	2~7 / 29~101	Push only	12 V d.c.	0.069 / 0.1518	VR10S511BV312A
	VR15	5/2	Sol./Sol.	Internal	2~7 / 29~101	2~7 / 29~101	Push only	12 V d.c.	0.093 / 0.2046	VR15S511BV312A
	VR10	5/2	Sol./Sol.	External	2~7 / 29~101	-1~7 / -14.5~101	Push only	24 V d.c.	0.069 / 0.1518	VR10S522BV313A
	VR15	5/2	Sol./Sol.	External	2~7 / 29~101	-1~7 / -14.5~101	Push only	24 V d.c.	0.093 / 0.2046	VR15S522BV313A
	VR10	5/2	Sol./Sol.	External	2~7 / 29~101	-1~7 / -14.5~101	Push only	12 V d.c.	0.069 / 0.1518	VR10S522BV312A
	VR15	5/2	Sol./Sol.	External	2~7 / 29~101	-1~7 / -14.5~101	Push only	12 V d.c.	0.093 / 0.2046	VR15S522BV312A
	VR10	5/2	Sol./Spring	Internal	2~7 / 29~101	2~7 / 29~101	Push only	24 V d.c.	0.061 / 0.1342	VR10S513BV313A
	VR15	5/2	Sol./Spring	Internal	2~7 / 29~101	2~7 / 29~101	Push only	24 V d.c.	0.084 / 0.1848	VR15S513BV313A
	VR10	5/2	Sol./Spring	Internal	2~7 / 29~101	2~7 / 29~101	Push only	12 V d.c.	0.061 / 0.1342	VR10S513BV312A
	VR15	5/2	Sol./Spring	Internal	2~7 / 29~101	2~7 / 29~101	Push only	12 V d.c.	0.084 / 0.1848	VR15S513BV312A
	VR10	5/2	Sol./Spring	External	2~7 / 29~101	-1~7 / -14.5~101	Push only	24 V d.c.	0.061 / 0.1342	VR10S523BV313A
	VR15	5/2	Sol./Spring	External	2~7 / 29~101	-1~7 / -14.5~101	Push only	24 V d.c.	0.084 / 0.1848	VR15S523BV313A
	VR10	5/2	Sol./Spring	External	2~7 / 29~101	-1~7 / -14.5~101	Push only	12 V d.c.	0.061 / 0.1342	VR10S523BV312A
	VR15	5/2	Sol./Spring	External	2~7 / 29~101	-1~7 / -14.5~101	Push only	12 V d.c.	0.084 / 0.1848	VR15S523BV312A

\*1) 12 V d.c. valves only for Multipole and CANopen / all solenoids are a 0.45 W energy saving type

### 5/3 Single and double solenoid actuated valves

Symbol	Series	Function	Actuation	Pilot Supply	Pilot Pressure (bar / psi)	Operating Pressure (bar / psi)	Manual Override	Voltage *1)	Weight (kg / lbs)	Model PNP
	VR10	5/3	APB	Internal	2~7 / 29~101	2~7 / 29~101	Push only	24 V d.c.	0.071 / 0.1562	VR10S611BV313A
	VR15	5/3	APB	Internal	2~7 / 29~101	2~7 / 29~101	Push only	24 V d.c.	0.100 / 0.220	VR15S611BV313A
	VR10	5/3	APB	Internal	2~7 / 29~101	2~7 / 29~101	Push only	12 V d.c.	0.071 / 0.1562	VR10S611BV312A
	VR15	5/3	APB	Internal	2~7 / 29~101	2~7 / 29~101	Push only	12 V d.c.	0.100 / 0.220	VR15S611BV312A
	VR10	5/3	APB	Extern	2~7 / 29~101	-1~7 / -14.5~101	Push only	24 V d.c.	0.071 / 0.1562	VR10S622BV313A
	VR15	5/3	APB	Extern	2~7 / 29~101	-1~7 / -14.5~101	Push only	24 V d.c.	0.100 / 0.220	VR15S622BV313A
	VR10	5/3	APB	Extern	2~7 / 29~101	-1~7 / -14.5~101	Push only	12 V d.c.	0.071 / 0.1562	VR10S622BV312A
	VR15	5/3	APB	Extern	2~7 / 29~101	-1~7 / -14.5~101	Push only	12 V d.c.	0.100 / 0.220	VR15S622BV312A
	VR10	5/3	COE	Internal	2~7 / 29~101	2~7 / 29~101	Push only	24 V d.c.	0.071 / 0.1562	VR10S711BV313A
	VR15	5/3	COE	Internal	2~7 / 29~101	2~7 / 29~101	Push only	24 V d.c.	0.100 / 0.220	VR15S711BV313A
	VR10	5/3	COE	Internal	2~7 / 29~101	2~7 / 29~101	Push only	12 V d.c.	0.071 / 0.1562	VR10S711BV312A
	VR15	5/3	COE	Internal	2~7 / 29~101	2~7 / 29~101	Push only	12 V d.c.	0.100 / 0.220	VR15S711BV312A
	VR10	5/3	COE	Extern	2~7 / 29~101	-1~7 / -14.5~101	Push only	24 V d.c.	0.071 / 0.1562	VR10S722BV313A
	VR15	5/3	COE	Extern	2~7 / 29~101	-1~7 / -14.5~101	Push only	24 V d.c.	0.100 / 0.220	VR15S722BV313A
	VR10	5/3	COE	Extern	2~7 / 29~101	-1~7 / -14.5~101	Push only	12 V d.c.	0.071 / 0.1562	VR10S722BV312A
	VR15	5/3	COE	Extern	2~7 / 29~101	-1~7 / -14.5~101	Push only	12 V d.c.	0.100 / 0.220	VR15S722BV312A
	VR10	5/3	COP	Internal	2~7 / 29~101	2~7 / 29~101	Push only	24 V d.c.	0.071 / 0.1562	VR10S811BV313A
	VR15	5/3	COP	Internal	2~7 / 29~101	2~7 / 29~101	Push only	24 V d.c.	0.100 / 0.220	VR15S811BV313A
	VR10	5/3	COP	Internal	2~7 / 29~101	2~7 / 29~101	Push only	12 V d.c.	0.071 / 0.1562	VR10S811BV312A
	VR15	5/3	COP	Internal	2~7 / 29~101	2~7 / 29~101	Push only	12 V d.c.	0.100 / 0.220	VR15S811BV312A
	VR10	5/3	COP	Extern	2~7 / 29~101	-1~7 / -14.5~101	Push only	24 V d.c.	0.071 / 0.1562	VR10S822BV313A
	VR15	5/3	COP	Extern	2~7 / 29~101	-1~7 / -14.5~101	Push only	24 V d.c.	0.100 / 0.220	VR15S822BV313A
	VR10	5/3	COP	Extern	2~7 / 29~101	-1~7 / -14.5~101	Push only	12 V d.c.	0.071 / 0.1562	VR10S822BV312A
	VR15	5/3	COP	Extern	2~7 / 29~101	-1~7 / -14.5~101	Push only	12 V d.c.	0.100 / 0.220	VR15S822BV312A

\*1) 12V d.c. valves only for Multipole and CANopen / all solenoids are a 0.45 W energy saving type

APB= All Ports Blocked  
 COE= Centre Open Exhaust  
 COP= Centre Open Port

### 2x 3/2 Double solenoid actuated valves

Symbol	Series	Function	Actuation	Pilot Supply	Pilot Pressure (bar / psi)	Operating Pressure (bar / psi)	Manual Override	Voltage *1)	Weight (kg / lbs)	Model PNP
	VR10	2X3/2	NC/NC	Internal	2~7 / 29~101	2~7 / 29~101	Push only	24 V d.c.	0.069 / 0.1518	VR10SA11BV313A
	VR15	2X3/2	NC/NC	Internal	2~7 / 29~101	2~7 / 29~101	Push only	24 V d.c.	0.092 / 0.2024	VR15SA11BV313A
	VR10	2X3/2	NC/NC	Internal	2~7 / 29~101	2~7 / 29~101	Push only	12 V d.c.	0.069 / 0.1518	VR10SA11BV312A
	VR15	2X3/2	NC/NC	Internal	2~7 / 29~101	2~7 / 29~101	Push only	12 V d.c.	0.092 / 0.2024	VR15SA11BV312A
	VR10	2X3/2	NC/NO	Internal	2~7 / 29~101	2~7 / 29~101	Push only	24 V d.c.	0.069 / 0.1518	VR10SC11BV313A
	VR15	2X3/2	NC/NO	Internal	2~7 / 29~101	2~7 / 29~101	Push only	24 V d.c.	0.092 / 0.2024	VR15SC11BV313A
	VR10	2X3/2	NC/NO	Internal	2~7 / 29~101	2~7 / 29~101	Push only	12 V d.c.	0.069 / 0.1518	VR10SC11BV312A
	VR15	2X3/2	NC/NO	Internal	2~7 / 29~101	2~7 / 29~101	Push only	12 V d.c.	0.092 / 0.2024	VR15SC11BV312A
	VR10	2X3/2	NO/NO	Internal	2~7 / 29~101	2~7 / 29~101	Push only	24 V d.c.	0.069 / 0.1518	VR10SB11BV313A
	VR15	2X3/2	NO/NO	Internal	2~7 / 29~101	2~7 / 29~101	Push only	24 V d.c.	0.092 / 0.2024	VR15SB11BV313A
	VR10	2X3/2	NO/NO	Internal	2~7 / 29~101	2~7 / 29~101	Push only	12 V d.c.	0.069 / 0.1518	VR10SB11BV312A
	VR15	2X3/2	NO/NO	Internal	2~7 / 29~101	2~7 / 29~101	Push only	12 V d.c.	0.092 / 0.2024	VR15SB11BV312A

\*1) 12 V d.c. valves only for Multipole and CANopen / all solenoids are a 0.45 W energy saving type

NC= Normally Closed  
 NO= Normally Open

### Sub-bases only

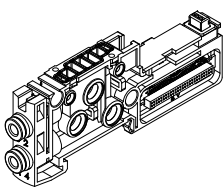
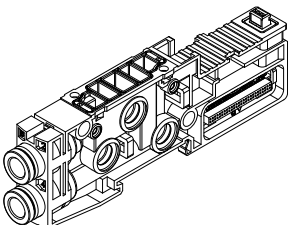
	Series	Port Size	Single / double wiring*	Weight (kg / lbs)	Model
	VR10	Ø4	Single	0.036 / 0.0792	VR107516BM1114
	VR10	Ø4	Double	0.036 / 0.0792	VR107516BM1124
	VR10	Ø6	Single	0.036 / 0.0792	VR107516BM1116
	VR10	Ø6	Double	0.036 / 0.0792	VR107516BM1126
	VR10	Ø5/32"	Single	0.036 / 0.0792	VR107516BM1111
	VR10	Ø5/32"	Double	0.036 / 0.0792	VR107516BM1121
	VR10	Ø1/4"	Single	0.036 / 0.0792	VR107516BM1119
	VR10	Ø1/4"	Double	0.036 / 0.0792	VR107516BM1129
	VR15	Ø4	Single	0.083 / 0.1826	VR157516BM1114
	VR15	Ø4	Double	0.083 / 0.1826	VR157516BM1124
	VR15	Ø6	Single	0.083 / 0.1826	VR157516BM1116
	VR15	Ø6	Double	0.083 / 0.1826	VR157516BM1126
	VR15	Ø8	Single	0.083 / 0.1826	VR157516BM1118
	VR15	Ø8	Double	0.083 / 0.1826	VR157516BM1128
	VR15	Ø5/32"	Single	0.083 / 0.1826	VR157516BM1111
	VR15	Ø5/32"	Double	0.083 / 0.1826	VR157516BM1121
	VR15	Ø1/4"	Single	0.083 / 0.1826	VR157516BM1119
	VR15	Ø1/4"	Double	0.083 / 0.1826	VR157516BM1129
	VR15	Ø5/16"	Single	0.083 / 0.1826	VR157516BM1110
	VR15	Ø5/16"	Double	0.083 / 0.1826	VR157516BM1120

\*Sub-bases are available in single and double wired versions. Single wired bases can only be used with single solenoid valves. Double wired bases can be used with both single solenoid and double solenoid valves

### Supply/Exhaust modules only

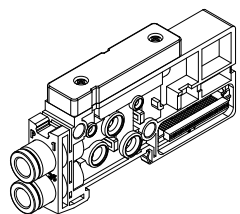
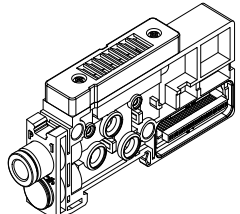
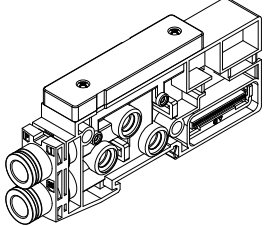
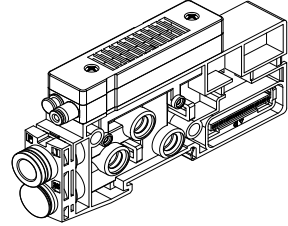
without silencer	with silencer	Series	Port Size	Pilot Supply	With Silencer	Weight (kg / lbs)	Model
		VR10	Ø8	Internal	Yes	0.071 / 0.1562	VR107516BMY108
		VR10	Ø8	External	Yes	0.091 / 0.2002	VR107516BMY208
		VR10	Ø8	Internal	No	0.071 / 0.1562	VR107516BMN108
		VR10	Ø8	External	No	0.091 / 0.2002	VR107516BMN208
		VR10	Ø5/16"	Internal	Yes	0.071 / 0.1562	VR107516BMY100
		VR10	Ø5/16"	External	Yes	0.091 / 0.2002	VR107516BMY200
		VR10	Ø5/16"	Internal	No	0.071 / 0.1562	VR107516BMN100
		VR10	Ø5/16"	External	No	0.091 / 0.2002	VR107516BMN200
		VR15	Ø10	Internal	Yes	0.105 / 0.231	VR157516BMY10Y
		VR15	Ø10	External	Yes	0.125 / 0.275	VR157516BMY20Y
		VR15	Ø10	Internal	No	0.105 / 0.231	VR157516BMN10Y
		VR15	Ø10	External	No	0.125 / 0.275	VR157516BMN20Y
		VR15	Ø3/8"	Internal	Yes	0.105 / 0.231	VR157516BMY101
		VR15	Ø3/8"	External	Yes	0.125 / 0.275	VR157516BMY201
		VR15	Ø3/8"	Internal	No	0.105 / 0.231	VR157516BMN101
		VR15	Ø3/8"	External	No	0.125 / 0.275	VR157516BMN201

### End Plate Only (IP65 Versions)

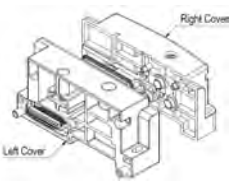
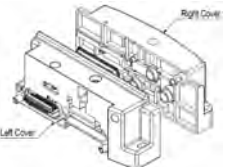
	Series	Cover Location	Weight (kg / lbs)	Model
	VR10	Right	0.06 / 0.132	VR107516BM0901
	VR10	Left	0.078 / 0.1716	VR107516BM0904
	VR15	Right	0.086 / 0.1892	VR157516BM0901
	VR15	Left	0.096 / 0.2112	VR157516BM0904

### VR10 & VR15 Control Modules (IP65 Version)

<p>PROFINET IRT</p> <p>VR1X7516BM02PN</p> <p>Weight: 0,223 kg</p>	<p>EtherNet/IP</p> <p>VR1X7516BM02EP</p> <p>Weight: 0,224 kg</p>	<p>CANopen</p> <p>VR1X7516BM02C1 - 12 V d.c.</p> <p>Weight: 0,221 kg</p>	<p>CANopen</p> <p>VR1X7516BM02C2 - 24 V d.c.</p> <p>Weight: 0,221 kg</p>	<p>EtherCAT</p> <p>VR1X7516BM02EC</p> <p>Weight: 0,221 kg</p>
<p>IO-Link</p> <p>VR1X7516BM02IL</p> <p>Weight: 0,181 kg</p>	<p>Multipole</p> <p>VR1X7516BM02M6</p> <p>Weight: 0,128 kg</p>			

### Industrial Ethernet - Cable and Connectors for PROFINET, EtherNet/IP and EtherCAT

<p>Bus cable: 4-pin D-coded M12 - M12</p> <table border="1"> <thead> <tr> <th>Model</th> <th>Cable length (m)</th> </tr> </thead> <tbody> <tr> <td>NC-124MS-1244SGA</td> <td>0.5</td> </tr> <tr> <td>NC-124MS-1244SG2</td> <td>2.0</td> </tr> <tr> <td>NC-124MS-1244SG5</td> <td>5.0</td> </tr> </tbody> </table>	Model	Cable length (m)	NC-124MS-1244SGA	0.5	NC-124MS-1244SG2	2.0	NC-124MS-1244SG5	5.0	<p>Bus cable: 4-pin D-coded M12 - flying lead</p> <table border="1"> <thead> <tr> <th>Model</th> <th>Cable length (m)</th> </tr> </thead> <tbody> <tr> <td>NC-124MS-00000G2</td> <td>2.0</td> </tr> <tr> <td>NC-124MS-00000G5</td> <td>5.0</td> </tr> </tbody> </table>	Model	Cable length (m)	NC-124MS-00000G2	2.0	NC-124MS-00000G5	5.0	<p>Bus cable: 4-pin D-coded RJ45 - M12</p> <table border="1"> <thead> <tr> <th>Model</th> <th>Cable length (m)</th> </tr> </thead> <tbody> <tr> <td>NC-RJ450-1244SG5</td> <td>5.0</td> </tr> </tbody> </table>	Model	Cable length (m)	NC-RJ450-1244SG5	5.0	<p>Bus connector RJ45 Wireable</p> <p>NC-RJ450-0000000</p>
Model	Cable length (m)																				
NC-124MS-1244SGA	0.5																				
NC-124MS-1244SG2	2.0																				
NC-124MS-1244SG5	5.0																				
Model	Cable length (m)																				
NC-124MS-00000G2	2.0																				
NC-124MS-00000G5	5.0																				
Model	Cable length (m)																				
NC-RJ450-1244SG5	5.0																				

Power cable: 5-pin A-coded M12 - flying lead

Model	Cable length (m)
NC-125FS-00000-5	5.0

### Fieldbus - Cable and Connectors for CANopen

<p>Bus cable: 5-pin A-coded M12 - flying lead</p> <table border="1"> <thead> <tr> <th>Model</th> <th>Cable length (m)</th> </tr> </thead> <tbody> <tr> <td>NC-125MS-00000L1</td> <td>1.0</td> </tr> <tr> <td>NC-125MS-00000L5</td> <td>5.0</td> </tr> </tbody> </table>	Model	Cable length (m)	NC-125MS-00000L1	1.0	NC-125MS-00000L5	5.0	<p>Bus connector: 5-pin A-coded (male) M12 - wireable</p> <p>NC-125MS-WIRE0A0</p>	<p>Terminating resistor (male) 5-pin A-coded M12</p> <p>NC-125MS-TERMRES</p>	<p>Power cable: 5-pin A-coded M12 - flying lead</p> <table border="1"> <thead> <tr> <th>Model</th> <th>Cable length (m)</th> </tr> </thead> <tbody> <tr> <td>NC-125FS-00000-5</td> <td>5.0</td> </tr> </tbody> </table>	Model	Cable length (m)	NC-125FS-00000-5	5.0
Model	Cable length (m)												
NC-125MS-00000L1	1.0												
NC-125MS-00000L5	5.0												
Model	Cable length (m)												
NC-125FS-00000-5	5.0												

## IO-Link - Cables

Cable 5-pin A-code  
M12 - M12



Model	Cable length (m)
NC-125FS-125MS-A	0.6
NC-125FS-125MS-1	1.0
NC-125FS-125MS-2	2.0
NC-125FS-125MS-5	5.0

Cable 5-pin A-code  
M12 - flying lead



Model	Cable length (m)
NC-125FS-00000-5	5.0

## Multipole (IP65) - Cables

D-Sub IP65 Connector Cable



V11569-E##  
## Insert 01 for 1 m,  
03 for 3 m and  
05 for 5 m

## Accessories

Blank Plug Kit (3pcs)



VR\*\*7516AM0400  
\*\* Insert 10 for VR10 or 15 for VR15

Blanking Plate



VR\*\*7516AM0300  
\*\* Insert 10 for VR10 or 15 for VR15

DIN Rail



VR\*\*7516AM08##  
\*\* Insert 10 for VR10 or 15 for VR15  
#Insert 06 for 2-6 stations  
10 for 7-10 stations  
15 for 11-15 stations  
20 for 16-20 stations  
24 for 21-24 stations

Tie Rod expansion Kit



VR\*\*7516MM07##NA  
\*\* Insert 10 for VR10 or 15 for VR15  
## Insert  
MS: ISEM expansion rod  
M1: 1 Station modular rod  
M2: 2 Stations modular rod

Tie Rod



VR\*\*7516MM07#\$  
\*\* Insert 10 for VR10 or 15 for VR15  
# Insert 02...24 for number of stations.  
# Insert 05...24 for number of stations.  
\$ Insert E1=1, E2 = 2, E3=3 and E4=4 for number of sup/exh modules

## Fitting Kits

Part Number	Description
VR107516AMFK01	Fitting Kit - VR10/15 External Pilot Base PIFØ4mm
VR107516AMFK02	Fitting Kit - VR10 Sub-Base PIFØ4mm
VR107516AMFK03	Fitting Kit - VR15 Sub-Base PIFØ4mm
VR107516AMFK04	Fitting Kit - VR10 Sub-Base PIFØ6mm
VR107516AMFK05	Fitting Kit - VR15 Sub-Base PIFØ4mm
VR107516AMFK06	Fitting Kit - VR10 ISEM / VR15 Sub-Base PIFØ8mm
VR107516AMFK07	Fitting Kit - VR15 ISEM PIFØ10mm
VR107516AMFK08	Fitting Kit - VR10 Sub-Base PIFØ5/32"
VR107516AMFK09	Fitting Kit - VR10/15 External Pilot Base PIFØ5/32"
VR107516AMFK10	Fitting Kit - VR15 Sub-Base PIFØ5/32"
VR107516AMFK11	Fitting Kit - VR10 Sub-Base PIFØ1/4"
VR107516AMFK12	Fitting Kit - VR15 Sub-Base PIFØ1/4"
VR107516AMFK13	Fitting Kit - VR10 ISEM / VR15 Sub-Base PIFØ5/16"
VR107516AMFK14	Fitting Kit - VR15 ISEM PIFØ3/8"

\* Fitting kits are supplied with 10-off fittings and 7-off locking pins

## Mounting Kits

Part Number	Description
VR107516AMMK01	Mounting Kit - Valve - 10mm
VR157516AMMK01	Mounting Kit - Valve - 15mm
VR107516AMMK02	Mounting Kit - Blank - 10mm
VR157516AMMK02	Mounting Kit - Blank - 15mm
VR107516AMMK03	Mounting Kit ISEM Int. - Blanking - 10mm
VR107516AMMK04	Mounting Kit ISEM Int. - Silencer - 10mm
VR107516AMMK06	Mounting Kit ISEM Ext. - Silencer - 10mm
VR107516AMMK07	Mounting Kit ISEM Ext. - Blanking - 10mm
VR157516AMMK03	Mounting Kit ISEM Int. - Blanking - 15mm
VR157516AMMK04	Mounting Kit ISEM Int. - Silencer - 15mm
VR157516AMMK06	Mounting Kit ISEM Ext. - Silencer - 15mm
VR157516AMMK07	Mounting Kit ISEM Ext. - Blanking - 15mm

\* Mounting kits are supplied with the required screws and sealings

## Exploded view (IP65)

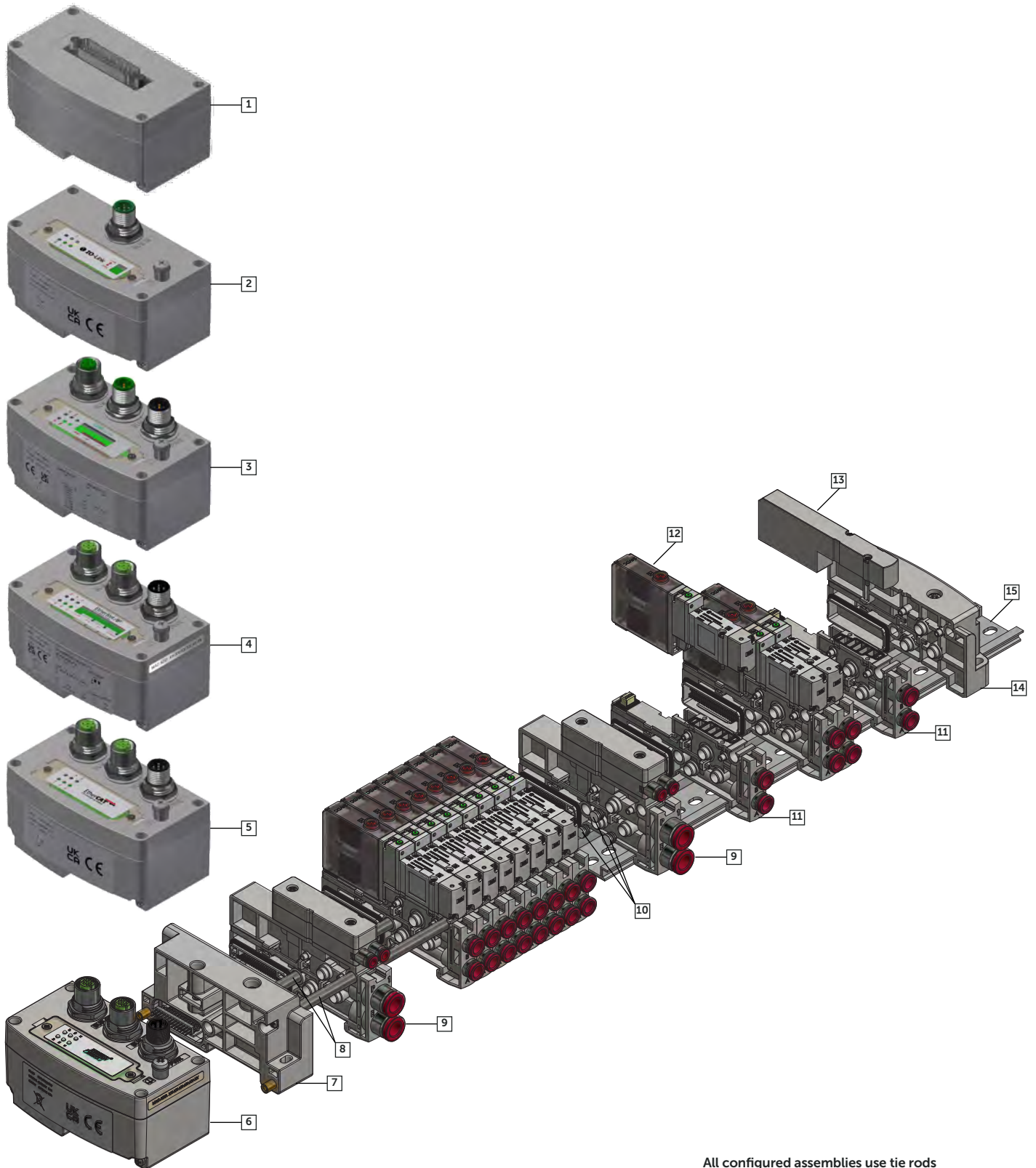

All configured assemblies use tie rods

- 1 Multipole control module
- 2 IO-Link control module
- 3 CANopen control module
- 4 EtherNet/IP control module
- 5 EtherCAT control module
- 6 PROFINET control module
- 7 Left Endplate (IP65)
- 8 Tie Rods

- 9 Sup/Exh module
- 10 Blank Plugs
- 11 Sub-Base
- 12 Valve slice
- 13 Blanking Plate
- 14 Right Endplate (IP65)
- 15 DIN Rail

# VR10 Series (Valve Island) Internal Pilot without Silencer (IP65 Version)

Dimensions in mm  
Projection/First angle

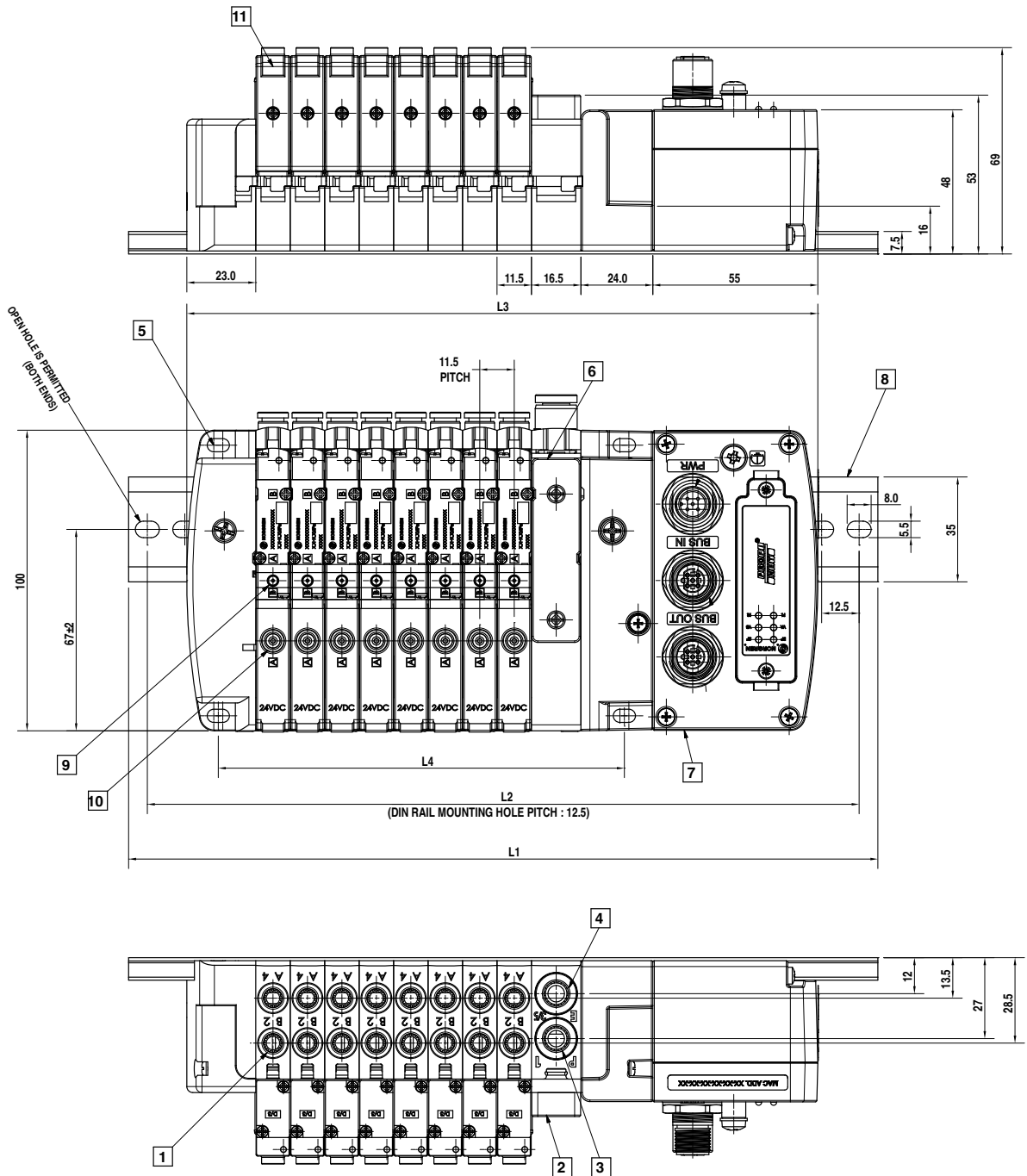

- 1 Outlet Port: PIF for tube O.D 4, O.D 6, O.D 5/32", O.D 1/4"
- 2 Sup/Exh module
- 3 Supply Port: PIF for tube O.D 8, O.D 5/16"
- 4 Exhaust Port: PIF for tube O.D 8, O.D 5/16"
- 5 Mounting 4x M4
- 6 Exhaust Port: Blank Plate
- 7 Control module
- 8 DIN Rail
- 9 Manual override (Port 2)
- 10 Manual override (Port 4)
- 11 LED

N:	2	3	4	5	6	7	8	9	10	11	12	13	14	15	16	17	18	19	20	21	22	23	24
L1 (mm)				200					250				300				387.5					437.5	
L2 (mm)			187.5						237.5				287.5				375					425	
L3 (mm)	141.5	153.0	164.5	176.0	187.5	199.0	210.5	222.0	233.5	261.5	273.0	284.5	296.0	307.5	319.0	330.5	342.0	353.5	365.0	376.5	388.0	399.5	411.0
L4 (mm)	66.5	78.0	89.5	101.0	112.5	124.0	135.5	147.0	158.5	186.5	198.0	209.5	221.0	232.5	244.0	255.5	267.0	278.5	290.0	301.5	313.0	324.5	336.0

\*2~10 stations: one Sup/Exh Module is required. 11~24 stations: two Sup/Exh Modules are recommended.

# VR10 Series (Valve Island) Internal Pilot with Silencer (IP65 Versions)

Dimensions in mm  
Projection/First angle

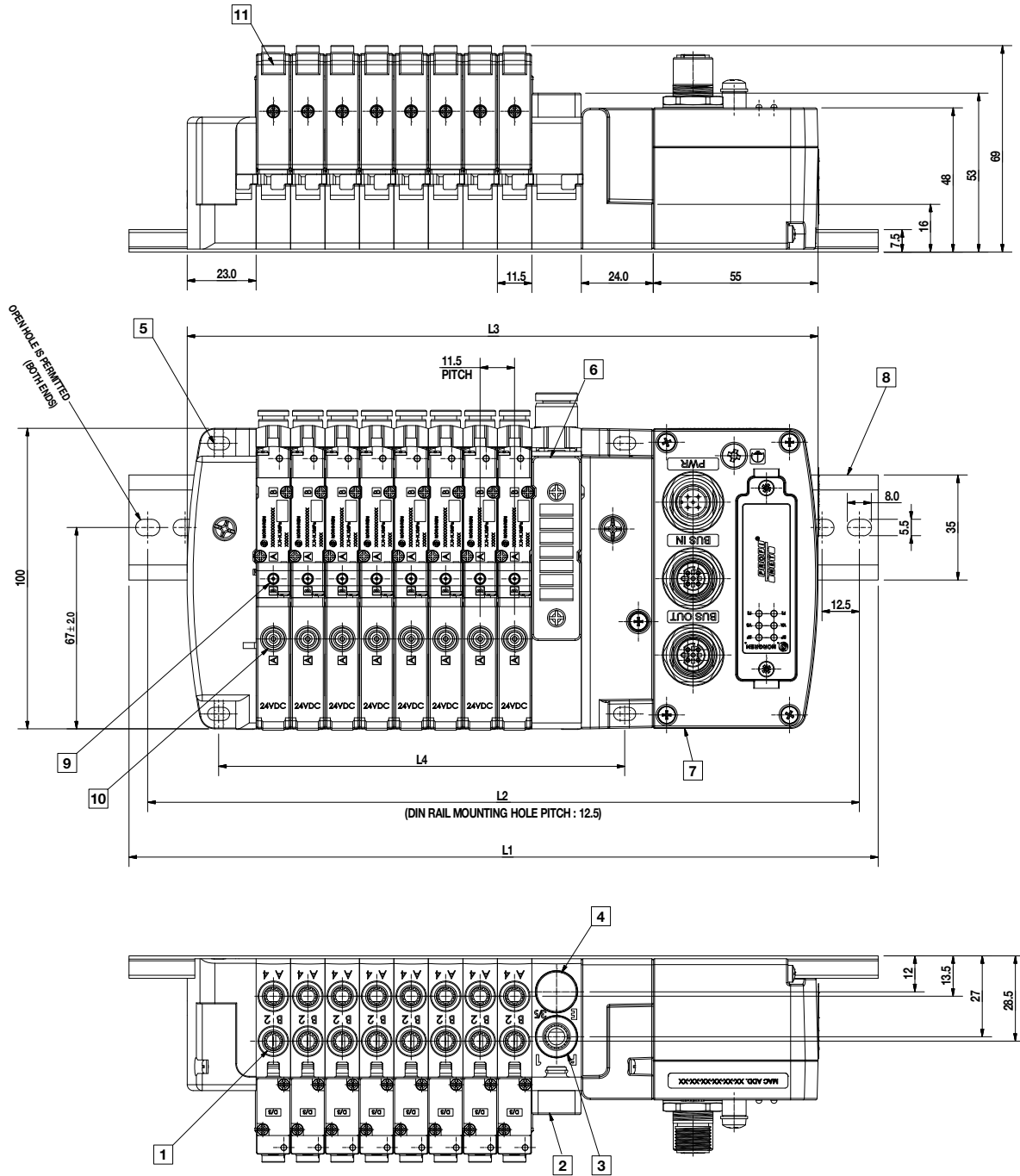

- 1 Outlet Port: PIF for tube O.D 4, O.D 6, O.D 5/32", O.D 1/4"
- 2 Sup/exh module
- 3 Supply Port: PIF for tube O.D 8, O.D 5/16"
- 4 Plug
- 5 Mounting 4x M4
- 6 Exhaust Port: Silencer Plate
- 7 Control module
- 8 DIN Rail
- 9 Manual override (Port 2)
- 10 Manual override (Port 4)
- 11 LED

N: Stations	2	3	4	5	6	7	8	9	10	11	12	13	14	15	16	17	18	19	20	21	22	23	24
L1 (mm)									250			300					387.5					437.5	
L2 (mm)			187.5						237.5			287.5					375					425	
L3 (mm)	141.5	153.0	164.5	176.0	187.5	199.0	210.5	222.0	233.5	261.5	273.0	284.5	296.0	307.5	319.0	330.5	342.0	353.5	365.0	376.5	388.0	399.5	411.0
L4 (mm)	66.5	78.0	89.5	101.0	112.5	124.0	135.5	147.0	158.5	186.5	198.0	209.5	221.0	232.5	244.0	255.5	267.0	278.5	290.0	301.5	313.0	324.5	336.0

\*2~10 stations: one Sup/Exh Module is required. 11~24 stations: two Sup/Exh Modules are recommended.

# VR10 Series (Valve Island) External Pilot without Silencer (IP65 Versions)

Dimensions in mm  
Projection/First angle

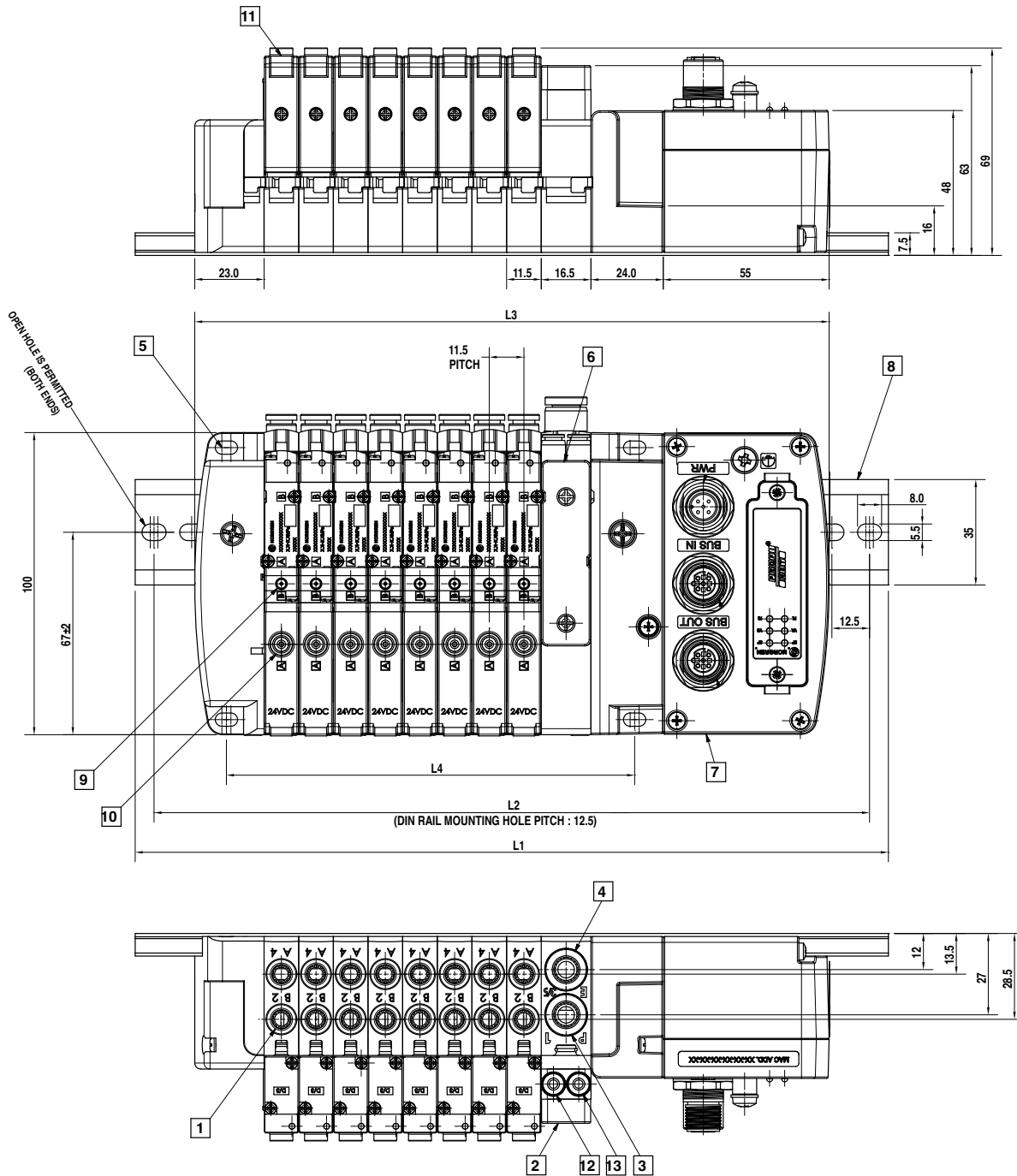

- 1 Outlet Port: PIF for tube O.D 4, O.D 6, O.D 5/32", O.D 1/4"
- 2 Sup/exh module
- 3 Supply Port: PIF for tube O.D 8, O.D 5/16"
- 4 Exhaust Port: PIF for tube O.D 8, O.D 5/16"
- 5 Mounting 4x M4
- 6 Exhaust Port: Blank Plate
- 7 Control module

- 8 DIN Rail
- 9 Manual override (Port 2)
- 10 Manual override (Port 4)
- 11 LED
- 12 Supply Port of external pilot: PIF for tube O.D. 4, O.D. 5/32"
- 13 Exhaust Port of external pilot: PIF for tube O.D. 4, O.D. 5/32"

N: Stations	2	3	4	5	6	7	8	9	10	11	12	13	14	15	16	17	18	19	20	21	22	23	24
L1 (mm)			200									300						387.5				437.5	
L2 (mm)			187.5					237.5				287.5						375				425	
L3 (mm)	141.5	153.0	164.5	176.0	187.5	199.0	210.5	222.0	233.5	261.5	273.0	284.5	296.0	307.5	319.0	330.5	342.0	353.5	365.0	376.5	388.0	399.5	411.0
L4 (mm)	66.5	78.0	89.5	101.0	112.5	124.0	135.5	147.0	158.5	186.5	198.0	209.5	221.0	232.5	244.0	255.5	267.0	278.5	290.0	301.5	313.0	324.5	336.0

\*2~10 stations: one Sup/Exh Module is required. 11~24 stations: two Sup/Exh Modules are recommended.



# VR15 Series (Valve Island) Internal Pilot without Silencer (IP65 Version)

Dimensions in mm  
Projection/First angle

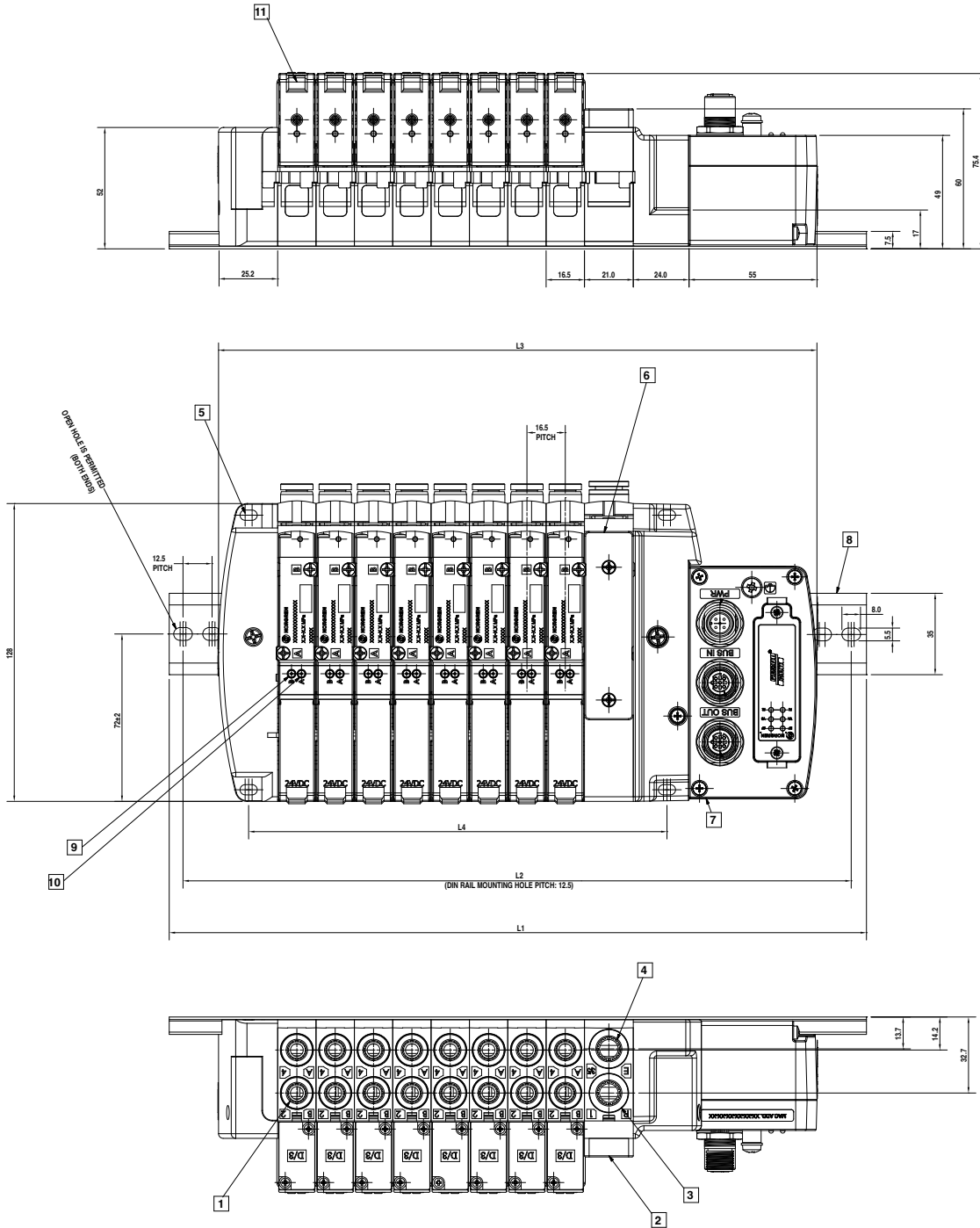

- |                                                                     |                             |
|---------------------------------------------------------------------|-----------------------------|
| 1 Outlet Port: PIF for tube O.D 4, O.D 6, O.D 8 O.D 5/32", O.D 1/4" | 7 Control module            |
| 2 Sup/Exh module                                                    | 8 DIN Rail                  |
| 3 Supply Port: PIF for tube O.D 10, O.D 3/8"                        | 9 Manual override (Port 2)  |
| 4 Exhaust Port: PIF for tube O.D 10, O.D 3/8"                       | 10 Manual override (Port 4) |
| 5 Mounting 4x M4                                                    | 11 LED                      |
| 6 Exhaust Port: Blank Plate                                         |                             |

N: Stations	2	3	4	5	6	7	8	9	10	11	12	13	14	15	16	17	18	19	20	21	22	23	24
L1 (mm)			250				300					400					500					587	
L2 (mm)		237.5					287.5					387.5					487.5					574.5	
L3 (mm)	158.2	174.7	191.2	207.7	224.2	240.7	257.2	273.7	290.2	327.7	344.2	360.7	377.2	393.7	410.2	426.7	443.2	459.7	476.2	492.7	509.2	525.7	542.2
L4 (mm)	81.0	97.5	114.0	130.5	147.0	163.5	180.0	196.5	213.0	250.5	267.0	283.5	300.0	316.5	333.0	349.5	366.0	382.5	399.0	415.5	432.0	448.5	465.0

\*2~10 stations: one Sup/Exh Module is required. 11~24 stations: two Sup/Exh Modules are recommended.

# VR15 Series (Valve Island) Internal Pilot with Silencer (IP65 Version)

Dimensions in mm  
Projection/First angle

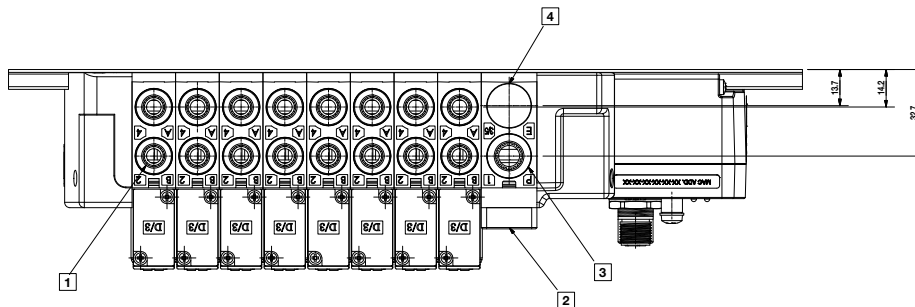
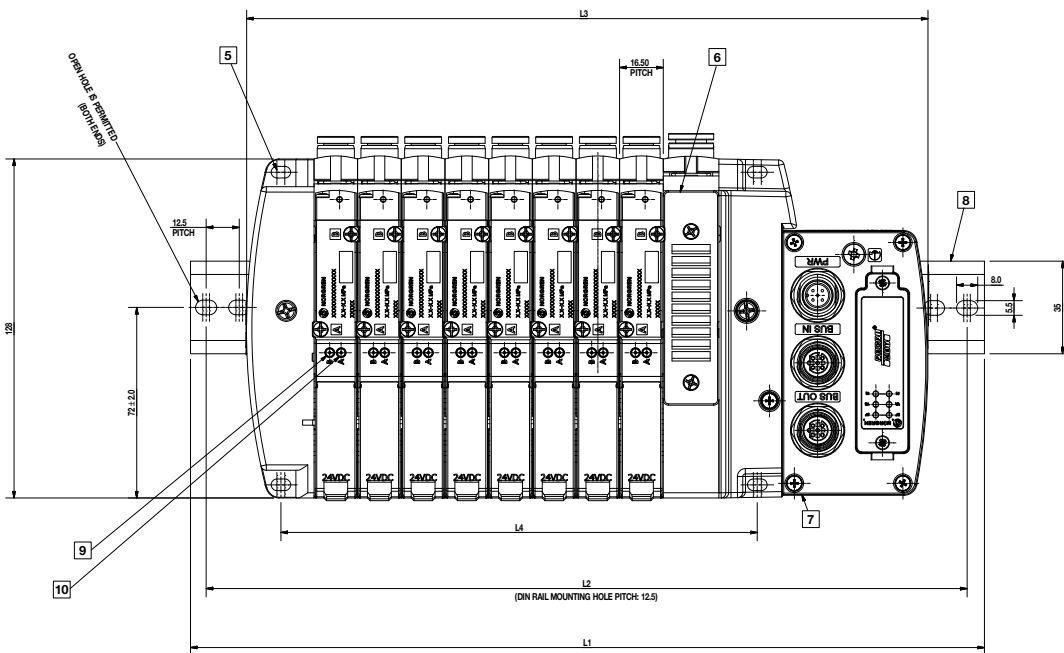
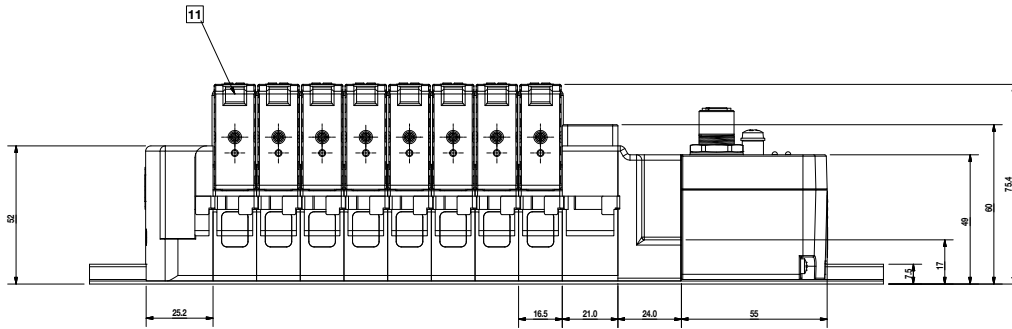

- 1 Outlet Port: PIF for tube O.D 4, O.D 6, 8 O.D, O.D 5/32", O.D 1/4"
- 2 Sup/exh module
- 3 Supply Port: PIF for tube O.D 10, O.D 3/8"
- 4 Plug of exhaust
- 5 Mounting 4x M4
- 6 Exhaust Port: Silencer Plate
- 7 Control module
- 8 DIN Rail
- 9 Manual override (Port 2)
- 10 Manual override (Port 4)
- 11 LED

N:	2	3	4	5	6	7	8	9	10	11	12	13	14	15	16	17	18	19	20	21	22	23	24
Stations																							
L1 (mm)			250					300					400					500				587	
L2 (mm)			237.5					287.5					387.5					487.5				574.5	
L3 (mm)	158.2	174.7	191.2	207.7	224.2	240.7	257.2	273.7	290.2	327.7	344.2	360.7	377.2	393.7	410.2	426.7	443.2	459.7	476.2	492.7	509.2	525.7	542.2
L4 (mm)	81.0	97.5	114.0	130.5	147.0	163.5	180.0	196.5	213.0	250.5	267.0	283.5	300.0	316.5	333.0	349.5	366.0	382.5	399.0	415.5	432.0	448.5	465.0

\*2~10 stations: one Sup/Exh Module is required. 11~24 stations: two Sup/Exh Modules are recommended.



# VR15 Series (Valve Island) External Pilot with Silencer (IP65 Version)

Dimensions in mm  
Projection/First angle

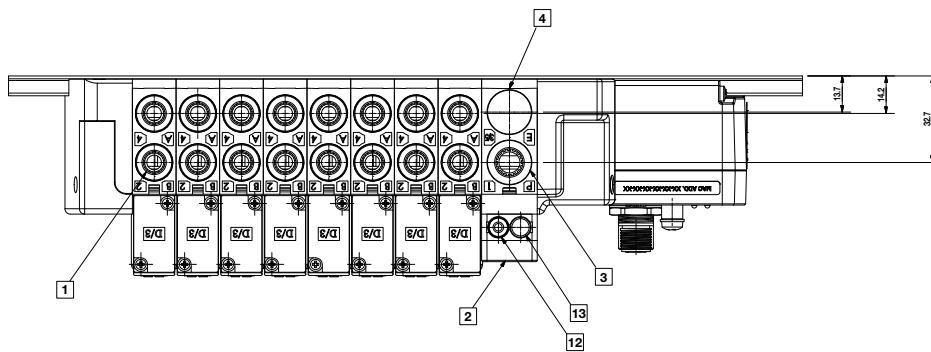
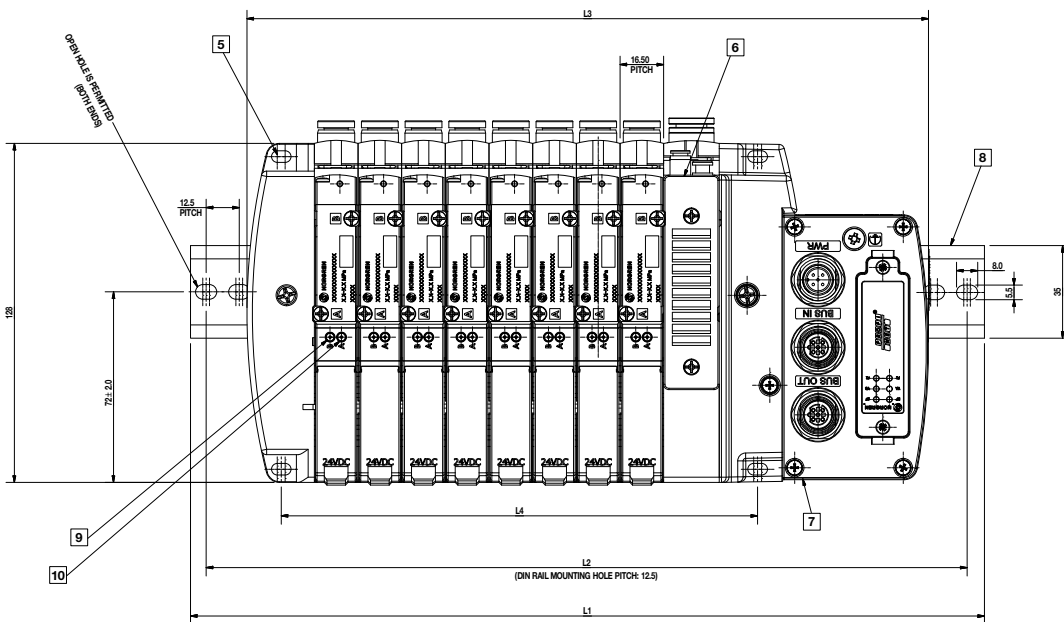
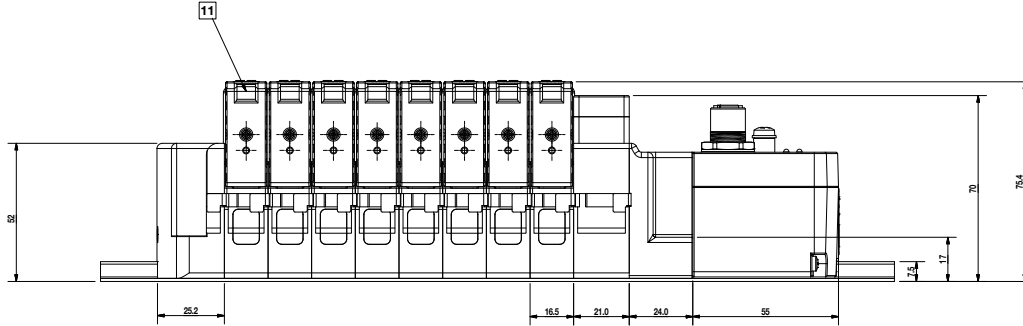

- 1 Outlet Port: PIF for tube O.D 4, O.D 6, 8 O.D, O.D 5/32", O.D 1/4"
- 2 Sup/exh module
- 3 Supply Port: PIF for tube O.D 10, O.D 3/8"
- 4 Plug
- 5 Mounting 4x M4
- 6 Exhaust Port: Silencer Plate
- 7 Control module
- 8 DIN Rail
- 9 Manual override (Port 2)
- 10 Manual override (Port 4)
- 11 LED
- 12 Supply Port of external pilot: PIF for tube O.D. 4, O.D. 5/32"
- 13 Plug

N: Stations	2	3	4	5	6	7	8	9	10	11	12	13	14	15	16	17	18	19	20	21	22	23	24
L1 (mm)			250					300										500					587
L2 (mm)			237.5					287.5										487.5					574.5
L3 (mm)	158.2	174.7	191.2	207.7	224.2	240.7	257.2	273.7	290.2	327.7	344.2	360.7	377.2	393.7	410.2	426.7	443.2	459.7	476.2	492.7	509.2	525.7	542.2
L4 (mm)	81.0	97.5	114.0	130.5	147.0	163.5	180.0	196.5	213.0	250.5	267.0	283.5	300.0	316.5	333.0	349.5	366.0	382.5	399.0	415.5	432.0	448.5	465.0

\*2~10 stations: one Sup/Exh Module is required. 11~24 stations: two Sup/Exh Modules are recommended.

## VR10 and VR15 Control Modules (IP65 Version)

Dimensions in mm  
Projection/First angle

**Multipole:**  
**Connector: 1 x D-Sub 25-pin**

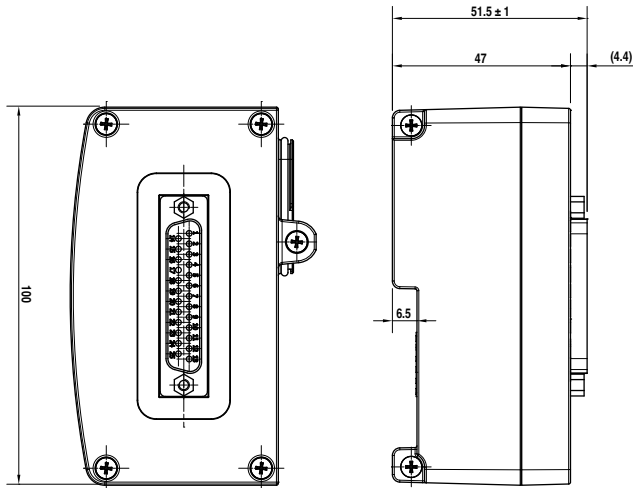

### D-Sub connector wiring



Pin no.	Wire colour	Solenoid	Pilot	Station
1	White	Solenoid 1-a	14	1
2	Brown	Solenoid 2-a	14	2
3	Green	Solenoid 3-a	14	3
4	Yellow	Solenoid 4-a	14	4
5	Grey	Solenoid 5-a	14	5
6	Pink	Solenoid 6-a	14	6
7	Blue	Solenoid 7-a	14	7
8	Red	Solenoid 8-a	14	8
9	Black	Solenoid 9-a	14	9
10	Violet	Solenoid 10-a	14	10
11	Grey/Pink	Solenoid 11-a	14	11
12	Red/Blue	Solenoid 12-a	14	12
13	White/Green	Common	--	--
14	Brown/Green	Solenoid 1-b	12	1
15	White/Yellow	Solenoid 2-b	12	2
16	Yellow/Brown	Solenoid 3-b	12	3
17	White/Grey	Solenoid 4-b	12	4
18	Grey/Brown	Solenoid 5-b	12	5
19	White/Pink	Solenoid 6-b	12	6
20	Pink/Brown	Solenoid 7-b	12	7
21	White/Blue	Solenoid 8-b	12	8
22	Brown/Blue	Solenoid 9-b	12	9
23	White/Red	Solenoid 10-b	12	10
24	Brown/Red	Solenoid 11-b	12	11
25	White/Black	Solenoid 12-b	12	12

\* This table is only applicable to the D-Sub cables that NORGRN supplies, IP65 version. Cable part numbers V11569-E01, V11569-E03 and V11569-E05.

\* The table indicates corresponding relation between pins, solenoids, pilots and stations based on configuration (12 stations, double solenoids) shown in table.

Valve islands exceeding 12 stations please refer to the Installation & Maintenance for Pin-Out

**IO-Link (Port Class B):**  
**Connector: 1 x M12 5-pin A-coded**



**Connector: M12 5-pin A-coded**

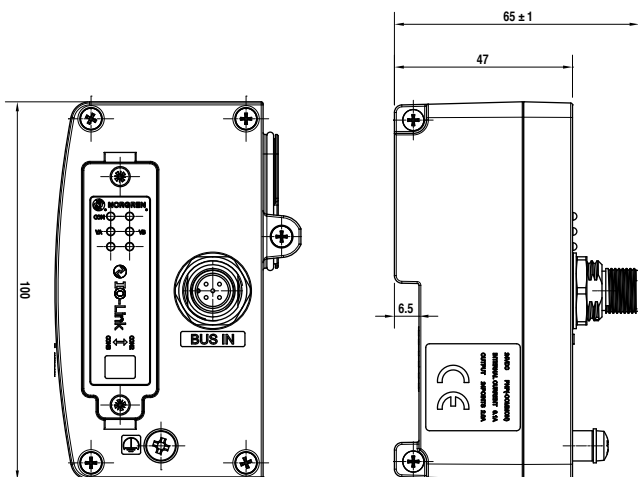

Male	Pin no.	Function	Tolerance	Max. current
	1	L+ (VB+) 24 V electronics power supply	+/- 10 %	max. 100 mA
	2	2L+ (VA+) 24 V valves power supply	+10 % / -5 %	n x 40 mA
	3	L- (VB-) 0 V electronics power supply		
	4	C/Q IO-Link communication		
	5	2M (VA-) 0 V valves power supply		

n = number of energized solenoids

## VR10 and VR15 Control Modules (IP65 Version)

Dimensions in mm  
Projection/First angle

Industrial Ethernet protocol: PROFINET IRT  
Connector: 2 x M12 4-pin / 1 x M12 5-pin



### Bus connector: M12 4-pin D-coded



Female	Pin no.	Function
	1	Transmission data + (TD +)
	2	Receive data + (RD+)
	3	Transmission data - (TD-)
	4	Receive data - (RD-)

### Power connector: M12 5-pin A-coded

Male	Pin no.	Function	Tolerance	Max. current
	1	L1 (VB+) 24 V electronics power supply	+/- 10 %	max. 100 mA
	2	N2 (VA-) 0 V valves power supply	-	-
	3	N1 (VB-) 0 V electronics power supply	-	-
	4	L2 (VA+) 24 V valves power supply	10 % +10 % / -5 %	n x 40 mA
	5	FE (functional earth)		

(n = number of switched valves)

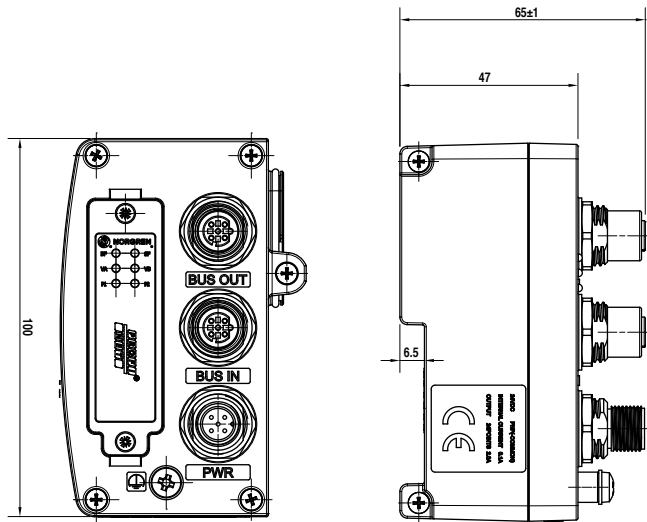

Industrial Ethernet protocol: EtherNet/IP  
Connector: 2 x M12 4-pin / 1 x M12 5-pin



### Bus connector: M12 4-pin D-coded

Female	Pin no.	Function
	1	Transmission data + (TD +)
	2	Receive data + (RD+)
	3	Transmission data - (TD-)
	4	Receive data - (RD-)

### Power connector: M12 5-pin A-coded

Male	Pin no.	Function	Tolerance	Max. current
	1	L1 (VB+) 24 V electronics power supply	+/- 10 %	max. 100 mA
	2	N2 (VA-) 0 V valves power supply	-	-
	3	N1 (VB-) 0 V electronics power supply	-	-
	4	L2 (VA+) 24 V valves power supply	10 % +10 % / -5 %	n x 40 mA
	5	FE (functional earth)		

(n = number of switched valves)

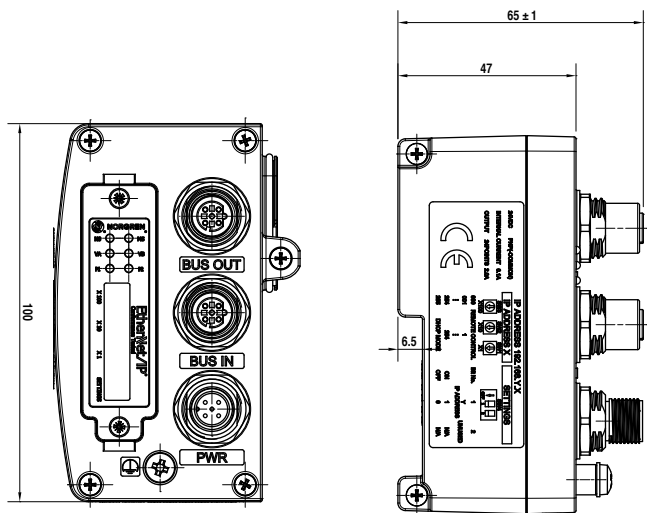

## VR10 and VR15 Control Modules (IP65 Version)

Dimensions in mm  
Projection/First angle

Industrial Ethernet protocol: EtherCAT  
Connector: 2 x M12 4-pin / 1 x M12 5-pin



Bus connector: M12 4-pin D-coded

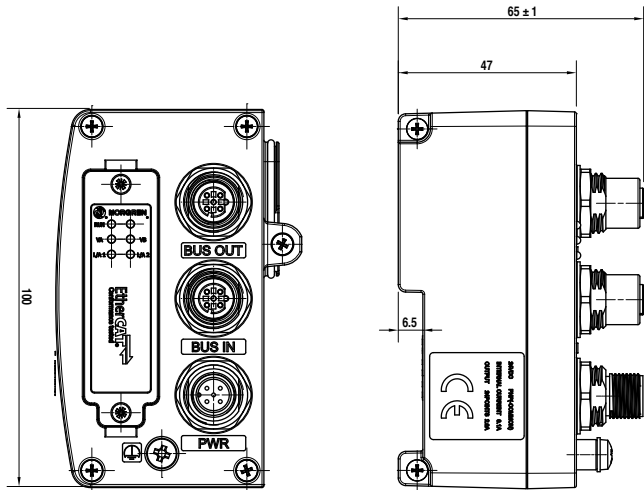

Female	Pin no.	Function
	1	Transmission data + (TD +)
	2	Receive data + (RD+)
	3	Transmission data - (TD-)
	4	Receive data - (RD-)

Power connector: M12 5-pin A-coded

Male	Pin no.	Function	Tolerance	Max. current
	1	L1 (VB+) 24 V electronics power supply	+/- 10 %	max. 100 mA
	2	N2 (VA-) 0 V valves power supply	-	-
	3	N1 (VB-) 0 V electronics power supply	-	-
	4	L2 (VA+) 24 V valves power supply	10 % +10 %/-5 %	n x 40 mA
	5	FE (functional earth)		

(n = number of switched valves)

Fieldbus protocol: CANopen  
Connector: 3 x M12 5-pin



Bus out connector: M12 5-pin A-coded

Female	Pin no.	Function
	1	Shield
	2	-
	3	Ground
	4	CAN_H
	5	CAN_L

Bus in connector: M12 5-pin A-coded

Male	Pin no.	Function
	1	Shield
	2	-
	3	Ground
	4	CAN_H
	5	CAN_L

Power connector: M12 5-pin A-coded

Male	Pin no.	Function	Tolerance	Max. current
	1	L1 (VB+) 24 V electronics power supply	+/- 10 %	max. 100 mA
	2	N2 (VA-) 0 V valves power supply	-	-
	3	N1 (VB-) 0 V electronics power supply	-	-
	4	L2 (VA+) 24 V valves power supply	10 % +10 %/-5 %	n x 40 mA
	5	FE (functional earth)		

(n = number of switched valves)

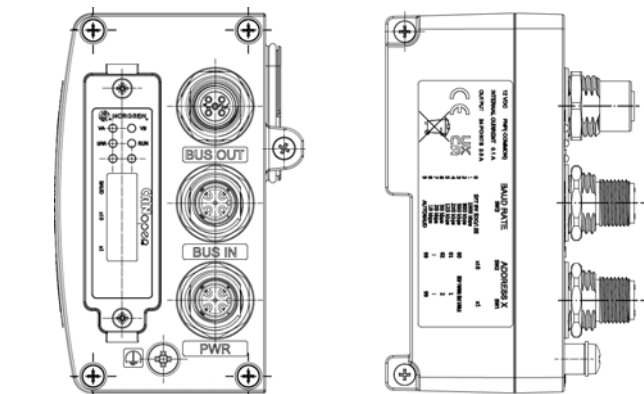

### VR10 Series (Valve) 2x3/2

### VR10 Series (Valve) 5/2

Dimensions in mm  
Projection/First angle

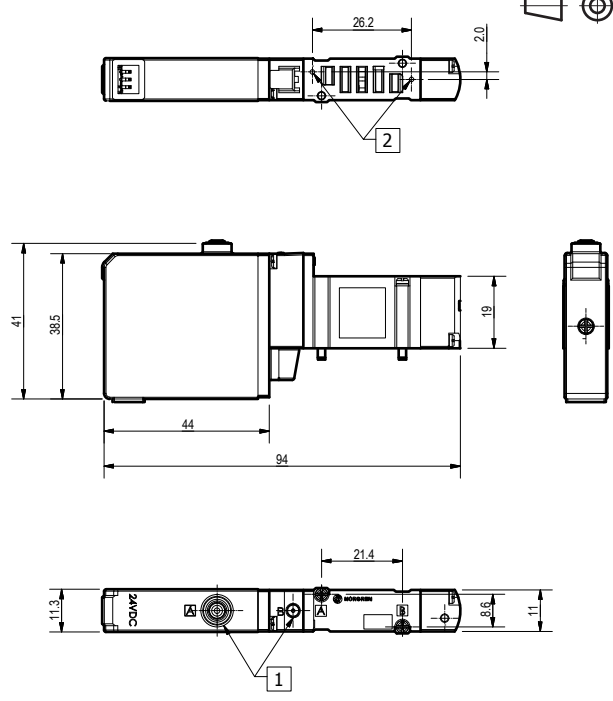
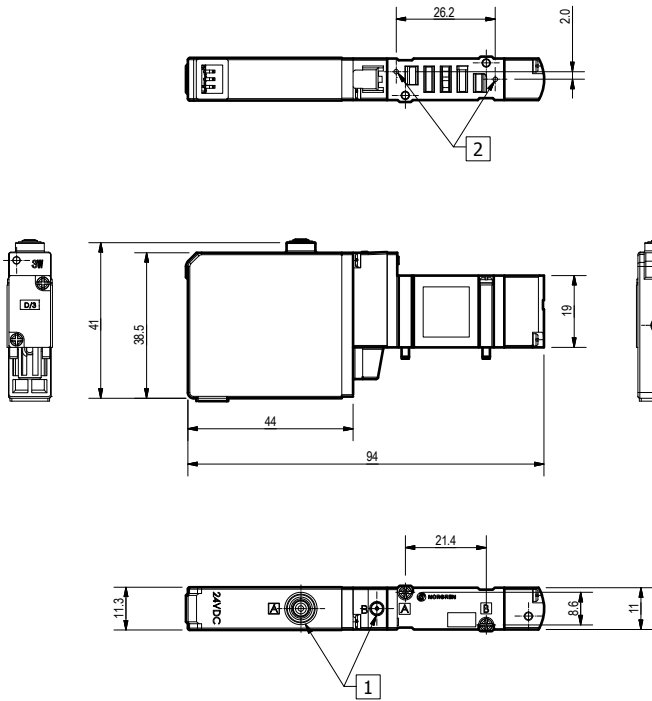

### VR10 Series (Valve) 5/3

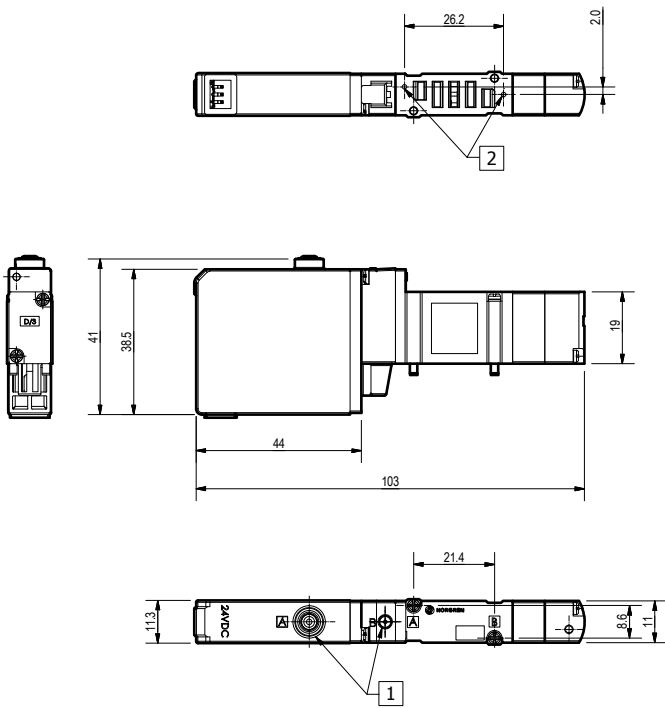

1 Manual override

2 Pilot supply holes

### VR15 Series (Valve) 2x3/2

Dimensions in mm  
Projection/First angle

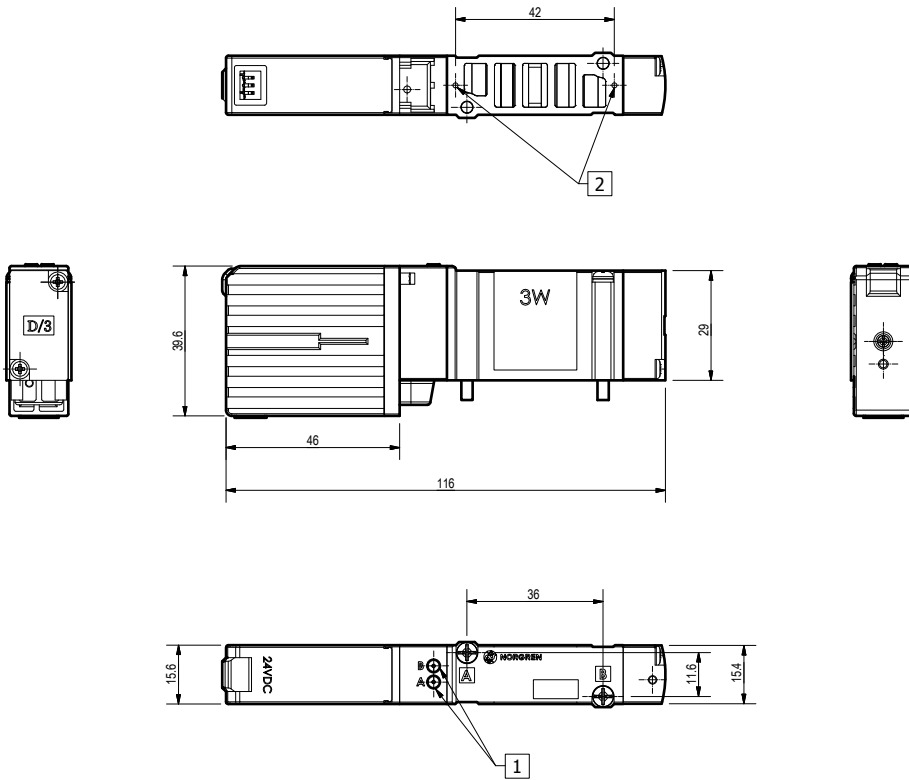

### VR15 Series (Valve) 5/2

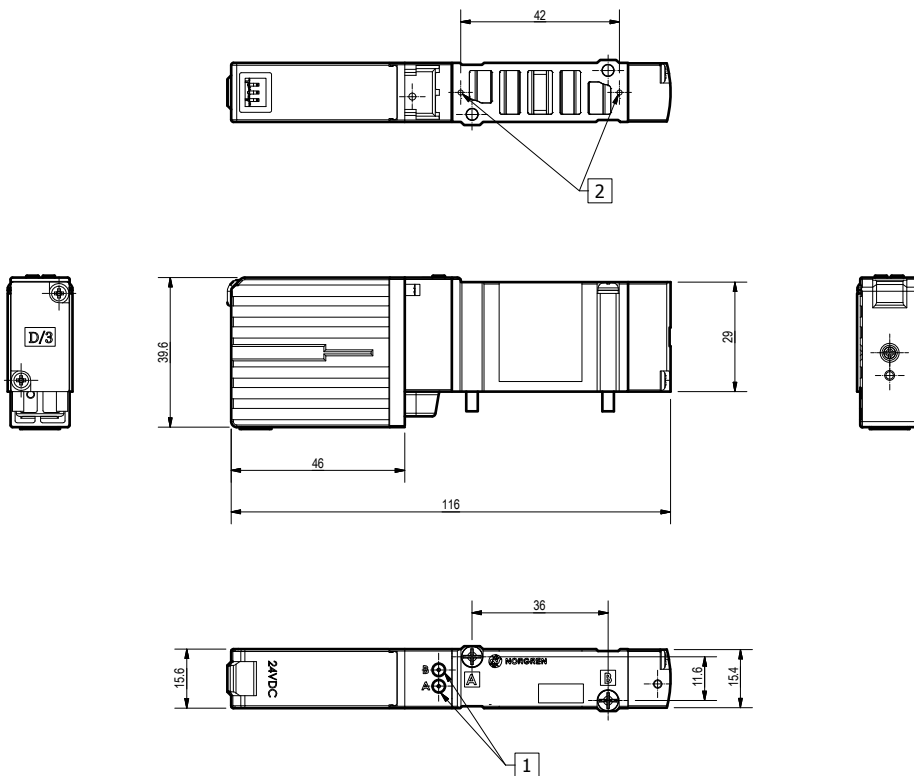

1 Manual override

2 Pilot supply holes

## VR15 Series (Valve) 5/3

Dimensions in mm  
Projection/First angle

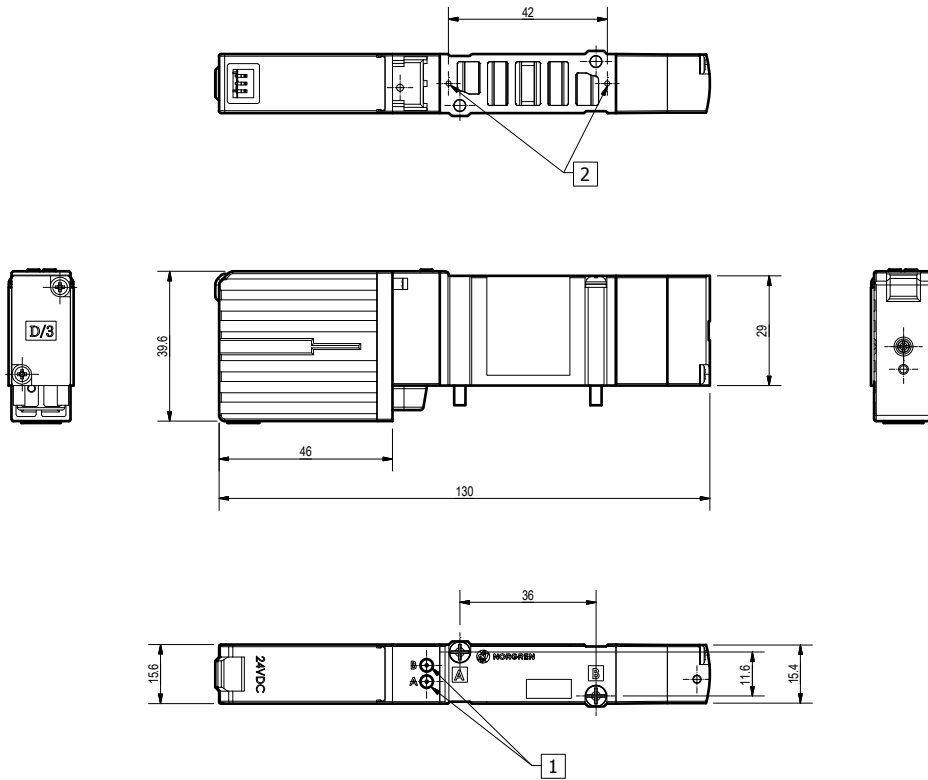

1 Manual override

2 Pilot supply holes

### Option selector - valve slices

VR\*\*S\*\*BV3\*\*3A

Series	Substitute
VR10	10
VR15	15
Spool Type	Substitute
Softseal Dynamic	S
Function	Substitute
5/2	5
5/3 APB	6
5/3 COE	7
5/3 COP	8
2x3/2 NC/NC*	A
2x3/2 NO/NO*	B
2x3/2 NC/NO*	C
Operator 14	Substitute
Solenoid Internal Pilot	1
Solenoid External Pilot	2

\* Internal Pilot Only

Connection	Substitute
Plug-in	A
Voltage	Substitute
12 V d.c. *1)	2
24 V d.c.	3
Electrical	Substitute
Common Positive (NPN) *2)	5
Common Negative (PNP)	1
Override	Substitute
Push only	3
Type	Substitute
Valve	V
Operator 12	Substitute
Solenoid Internal Pilot	1
Solenoid External Pilot	2
Air Spring Return	3

\*1) only for Multipole and CANopen

\*2) only for Multipole

### Option selector - blank plate

VR\*\*7516 A M 0300

Series	Substitute
VR10	10
VR15	15
Type	Substitute
Component	7516
Standard	A

Option	Substitute
Blank Plate	0300
Type	Substitute
Manifold	M

### Option selector - Sub-base

VR\*\*7516 B M 11 \*\*

Series	Substitute
VR10	10
VR15	15
Type	Substitute
Component	7516
Type	Substitute
Manifold	M
Option	Substitute
Sub-base	11
Base Style	Substitute
Single Wiring	1
Double Wiring	2

Fitting Size	Substitute
4mm PIF VR10	4
6mm PIF VR10	6
5/32" PIF VR10	1
1/4" PIF VR10	9
4mm PIF VR15	4
6mm PIF VR15	6
8mm PIF VR15	8
5/32" PIF VR15	1
1/4" PIF VR15	9
5/16" PIF VR15	0

### Option selector - End Plate IP65

VR\*\*7516 B M \*\* \*\*

Series	Substitute
VR10	10
VR15	15
Type	Substitute
Component	7516
IP Rating	Substitute
IP65	B

Base Style	Substitute
End Plate (Right Side)	01
End Plate (Left Side)	04
Option	Substitute
End Plate	09
Type	Substitute
Manifold	M

Warning: For IP65 with silencers option, silencers are not recommended in wash down or very dusty applications.

### Option selector - Supply/Exhaust Module

VR\*\*7516 B M \*\* 0 \*

Series	Substitute
VR10	10
VR15	15
Type	Substitute
Component	7516
Type	Substitute
Manifold	M

Fitting Size	Substitute
8mm PIF	VR10 8
5/16" PIF	VR10 0
10mm PIF	VR15 Y
3/8" PIF	VR15 1
Base Style	Substitute
Internal Pilot Base	1
External Pilot Base	2
Silencer Incorporated	Substitute
No	N
Yes	Y

### Option selector - Tie Rod

VR\*\*7516 M M 07 \*\* \*\*

Series	Substitute
VR10	10
VR15	15
Type	Substitute
Component	7516
Option	Substitute
Modular	M
Type	Substitute
Manifold	M
Component Type	Substitute
Tie-rod Assembly	07

Number of Supply/Exhaust Modules Used	Substitute
1 Supply/Exhaust Module	E1
2 Supply/Exhaust Module	E2
3 Supply/Exhaust Module	E3
4 Supply/Exhaust Module	E4
Number of Stations	Substitute
2 stations	02
3 stations	03
4 stations	04
5 stations	05
6 stations	06
7 stations	07
8 stations	08
9 stations	09
10 stations	10
11 stations	11
12 stations	12
13 stations	13
14 stations	14
15 stations	15
16 stations	16
17 stations	17
18 stations	18
19 stations	19
20 stations	20
21 stations	21
22 stations	22
23 stations	23
24 stations	24

### Option Selector - DIN Rail

VR \*\* 7516 A M 08 \*\*

Series	Substitute
VR10	10
VR15	15
Type	Substitute
Component	7516
Option	Substitute
Standard	A
Type	Substitute
Manifold	M
Component Type	Substitute
DIN Rail	08

Length	Substitute
06 = 2-6 stations	06
10 = 7-10 stations	10
15 = 11-15 stations	15
20 = 16-20 stations	20
24 = 21-24 stations	24

### Option selector - Control Modules IP65

VR1X7516 B M 02 \*\*

Type	Substitute
Component	7516
IP Rating	Substitute
IP65	B
Type	Substitute
Manifold	M

Control	Substitute
EtherCAT *1)	EC
EtherNet/IP *1)	EP
IO-Link *1)	IL
PROFINET *1)	PN
CANopen 12 V d.c.	C1
CANopen 24 V d.c.	C2
Multipole D-Sub	M6
Option	Substitute
Module	02

\*1) only for use with PNP valves

## IP40 Options End Plate Only (for IP40 Multipole Versions)

	Series	Connector Type	Connector	Cover Location	Orientation	Weight (kg)	Model
	VR10	--	None	Right	--	0.060	VR107516BM0901
	VR10	D-Sub Connector 25-Pin	D-Sub	Left	Horizontal	0.105	VR107516AM0902
	VR10	D-Sub Connector 25-Pin	D-Sub	Left	Vertical	0.105	VR107516AM0903
	VR15	--	None	Right	--	0.086	VR157516BM0901
	VR15	D-Sub Connector 25-Pin	D-Sub	Left	Horizontal	0.131	VR157516AM0902
	VR15	D-Sub Connector 25-Pin	D-Sub	Left	Vertical	0.131	VR157516AM0903

### Option selector - End Plate IP40 Multipole

Series	Substitute
VR10	10
VR15	15
Type	Substitute
Component	7516
IP Rating	Substitute
IP40	A

VR★ ★ 7516 A M ★ ★ ★ ★



Base Style	Substitute
End Plate (Right Side)	01
Multipole Horizontal D-Sub Connector (Left Side)	02
Multipole Vertical D-Sub Connector (Left Side)	03
Option	Substitute
End Plate	09
Type	Substitute
Manifold	M

### Multipole (IP40 only) - Cables

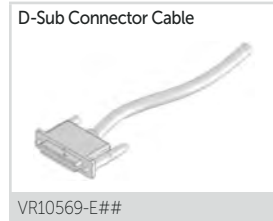

## Insert 15 for 1.5m,  
03 for 3m and  
05 for 5m

### Multipole (IP40): Connector: 1 x D-Sub 25-pin

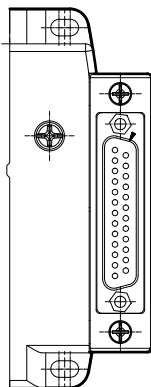

\* This table is only applicable to the D-Sub cables that NORGREN supplies, IP40 version. Cable part numbers VR10569-E15, VR10569-E03 and VR10569-E05.

The table indicates corresponding relation between pins, solenoids, pilots and stations based on configuration (12 stations, double solenoids) shown in table. Valve islands exceeding 12 stations please refer to the Installation & Maintenance for Pin-Out

### D-Sub connector wiring

Pin no.	Wire colour	Socket	Pilot	Station
1	Black	Solenoid 1-a	14	1
2	Black, White	Solenoid 2-a	14	2
3	Brown	Solenoid 3-a	14	3
4	Brown, White	Solenoid 4-a	14	4
5	Red	Solenoid 5-a	14	5
6	Red, Yellow	Solenoid 6-a	14	6
7	Red, White	Solenoid 7-a	14	7
8	Pink	Solenoid 8-a	14	8
9	Pink, White	Solenoid 9-a	14	9
10	Yellow	Solenoid 10-a	14	10
11	Yellow, Red	Solenoid 11-a	14	11
12	Yellow, Blue	Solenoid 12-a	14	12
13	Green	Common	--	--
14	Green, Yellow	Solenoid 1-b	12	1
15	Green, White	Solenoid 2-b	12	2
16	Blue	Solenoid 3-b	12	3
17	Blue, Yellow	Solenoid 4-b	12	4
18	Blue, White	Solenoid 5-b	12	5
19	Violet	Solenoid 6-b	12	6
20	Violet, White	Solenoid 7-b	12	7
21	Gray	Solenoid 8-b	12	8
22	Gray, Red	Solenoid 9-b	12	9
23	White	Solenoid 10-b	12	10
24	White, Red	Solenoid 11-b	12	11
25	White, Blue	Solenoid 12-b	12	12

## Part numbering for complete valve islands

VR\*\*\*\*\*00-\*\*\*\*\*

Series	Substitute
VR10	10
VR15	15
Number of stations	Substitute
2 stations	02
3 stations	03
4 stations	04
5 stations	05
6 stations	06
7 stations	07
8 stations	08
9 stations	09
10 stations	10
11 stations	11
12 stations	12
13 stations	13
14 stations	14
15 stations	15
16 stations	16
17 stations	17
18 stations	18
19 stations	19
20 stations	20
21 stations	21
22 stations	22
23 stations	23
24 stations	24
Electrical connection	Substitute
EtherCAT	EC
EtherNet/IP	EP
IO-Link	IL
PROFINET	PN
IP40 Multipole D-Sub 25pin	M2
P65 Multipole D-Sub 25pin	M6
CANopen 12 V d.c.	C1
CANopen 24 V d.c.	C2

To be defined by online Valve Island configurator based on valve slice selection

To configure and order a valve island visit - <https://www.norgren.com/en/support/configurators/valve-island-configurators>

### VR10 Exploded view (IP40 Multipole Versions)

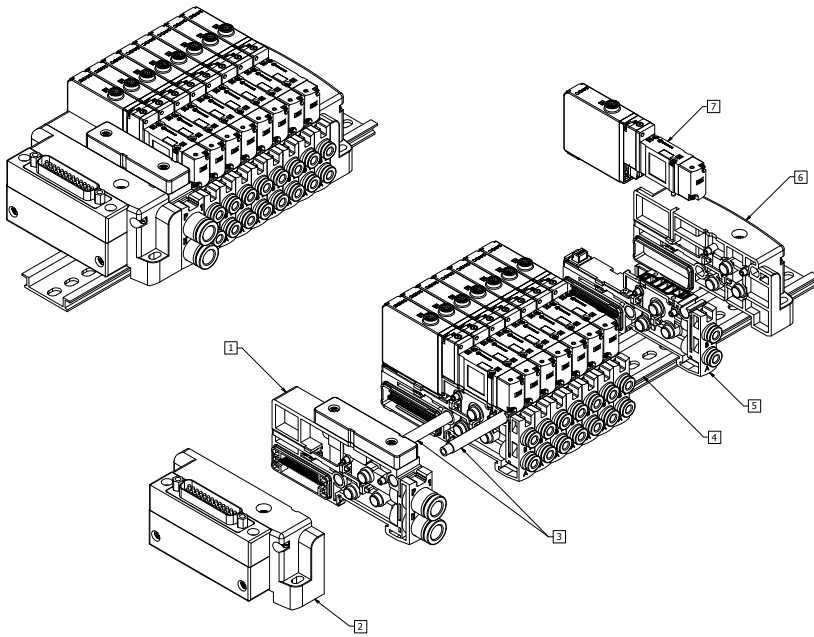

- 1 Sup/exh module
- 2 Left End Plate
- 3 Tie Rod
- 4 DIN Rail
- 5 Sub-base
- 6 Right End Plate
- 7 Valve

### VR15 Exploded view (IP40 Multipole Versions)

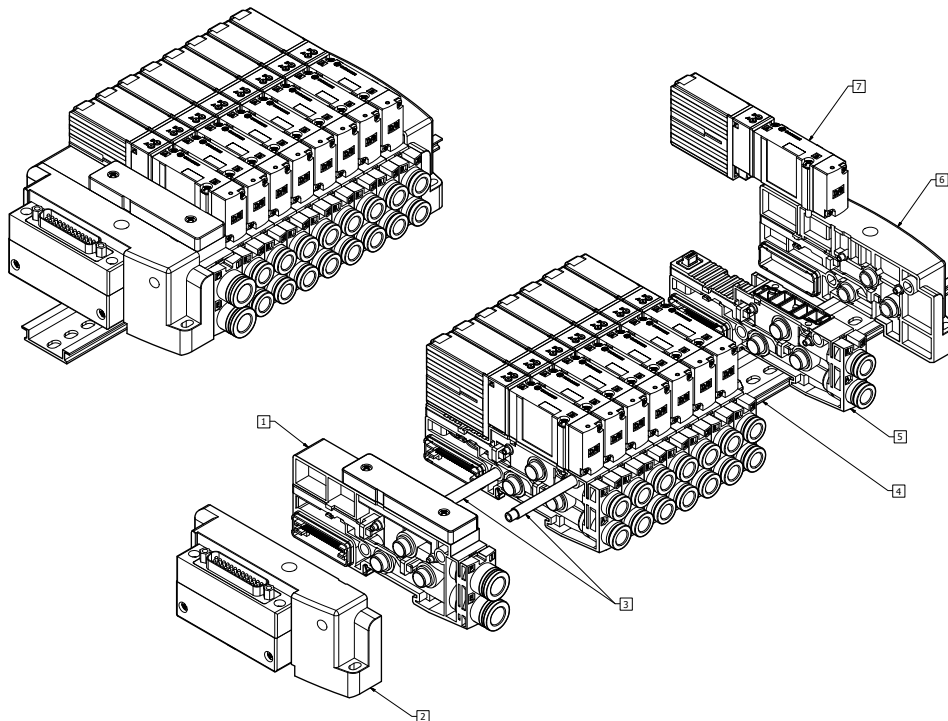

- 1 Sup/exh module
- 2 Left End Plate
- 3 Tie Rod
- 4 DIN Rail
- 5 Sub-base
- 6 Right End Plate
- 7 Valve

All configured assemblies use tie rods

# VR10 Series (Valve Island) Internal Pilot without Silencer (IP40 Multipole Versions)

Dimensions in mm  
Projection/First angle

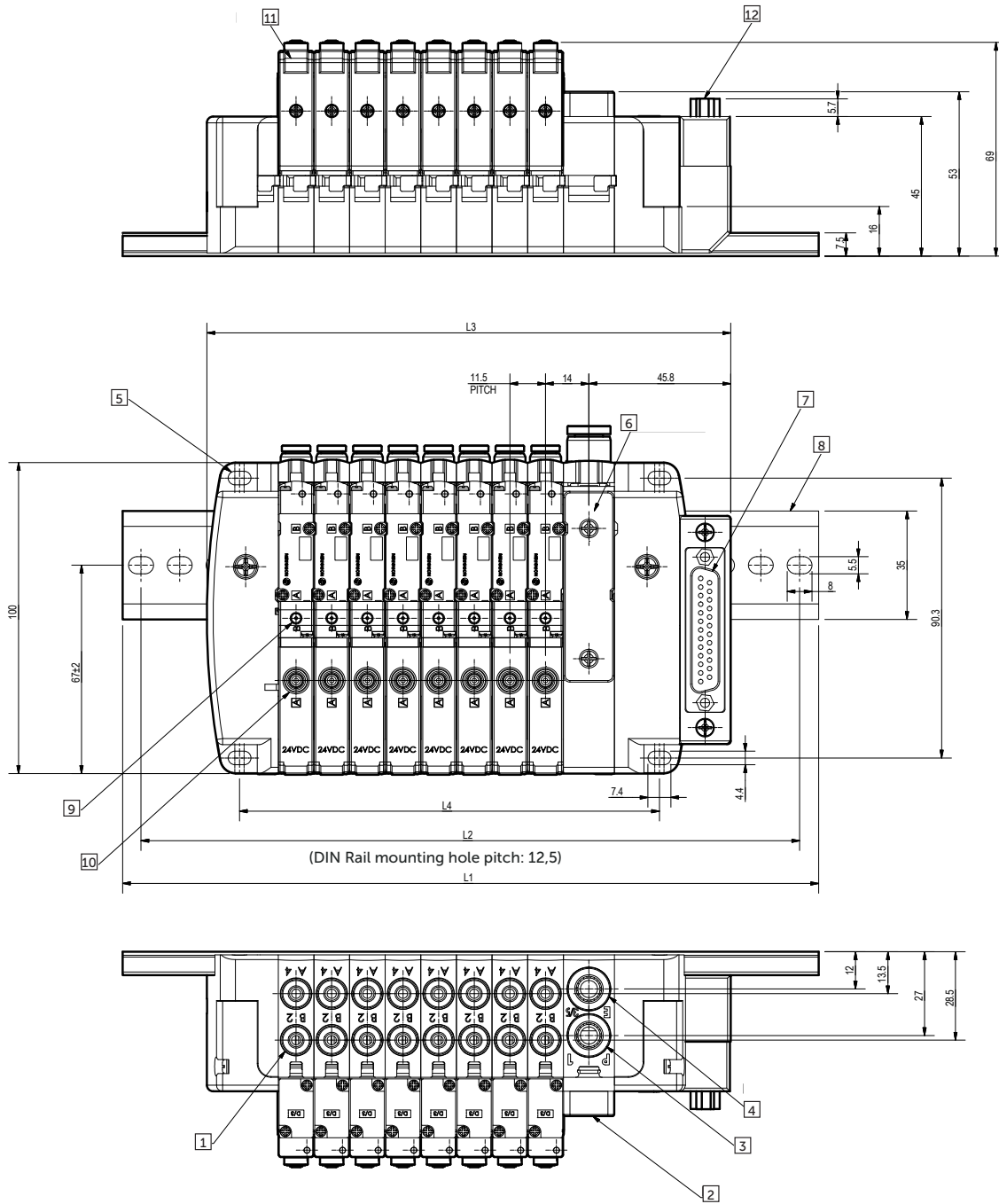

- 1 Outlet Port: PIF for tube O.D 4, O.D 6, O.D 5/32", O.D 1/4"
- 2 Sup/Exh module
- 3 Supply Port: PIF for tube O.D 8, O.D 5/16"
- 4 Exhaust Port: PIF for tube O.D 8, O.D 5/16"
- 5 Mounting 4x M4
- 6 Exhaust Port: Blank Plate

- 7 Applicable connector: D-Sub Connector 25 Pin
- 8 DIN Rail
- 9 Manual override (Port 2)
- 10 Manual override (Port 4)
- 11 LED
- 12 Connector direction: vertical or horizontal

N:	2	3	4	5	6	7	8	9	10	11	12	13	14	15	16	17	18	19	20	21	22	23	24
L1 (mm)			200					250				300					387.5			437.5			
L2 (mm)		187.5						237.5				287.5					375			425			
L3 (mm)	100	111.5	123	134.5	146	157.5	169	180.5	192	220	231.5	243	254.5	266	277.5	289	300.5	312	323.5	335	346.5	358	369.5
L4 (mm)	66.5	78	89.5	101	112.5	124	135.5	147	158.5	186.5	198	209.5	221	232.5	244	255.5	267	278.5	290	301.5	313	324.5	336

\*2~10 stations: one Sup/Exh Module is required. 11~24 stations: two Sup/Exh Modules are recommended.

# VR10 Series (Valve Island) Internal Pilot with Silencer (IP40 Multipole Versions)

Dimensions in mm  
Projection/First angle

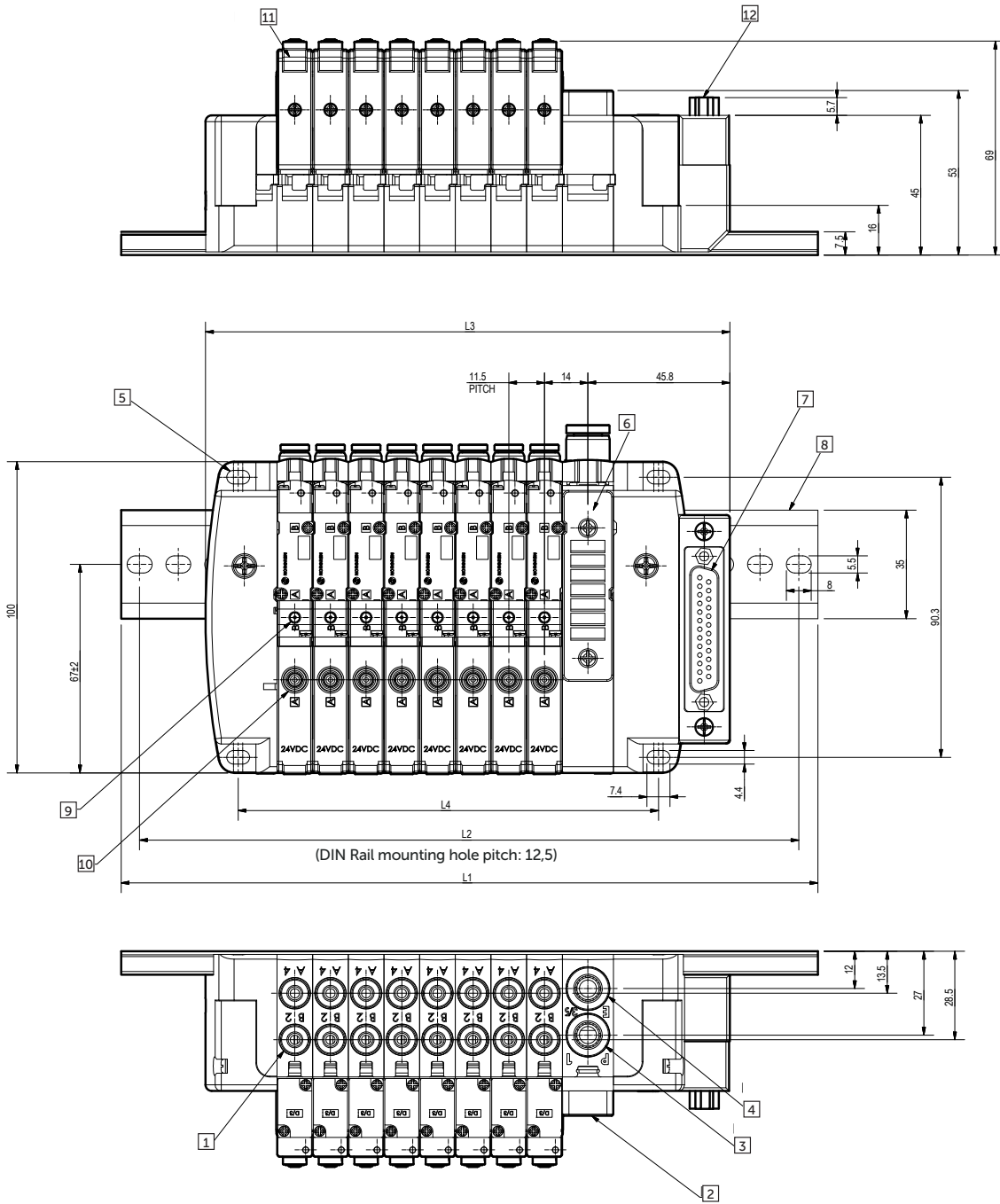

- 1 Outlet Port: PIF for tube O.D 4, O.D 6, O.D 5/32", O.D 1/4"
- 2 Sup/exh module
- 3 Supply Port: PIF for tube O.D 8, O.D 5/16"
- 4 Exhaust Port: PIF for tube O.D 8, O.D 5/16"
- 5 Mounting 4x M4
- 6 Exhaust Port: Silencer plate

- 7 Applicable connector: D-Sub Connector 25 Pin
- 8 DIN Rail
- 9 Manual override (Port 2)
- 10 Manual override (Port 4)
- 11 LED
- 12 Connector direction: vertical or horizontal

N:	2	3	4	5	6	7	8	9	10	11	12	13	14	15	16	17	18	19	20	21	22	23	24	
L1 (mm)	200			250			300			387.5			437.5											
L2 (mm)	187.5			237.5			287.5			375			425											
L3 (mm)	100	111.5	123	134.5	146	157.5	169	180.5	192	220	231.5	243	254.5	266	277.5	289	300.5	312	323.5	335	346.5	358	369.5	
L4 (mm)	66.5	78	89.5	101	112.5	124	135.5	147	158.5	186.5	198	209.5	221	232.5	244	255.5	267	278.5	290	301.5	313	324.5	336	

\*2~10 stations: one Sup/Exh Module is required. 11~24 stations: two Sup/Exh Modules are recommended.

# VR10 Series (Valve Island) External Pilot without Silencer (IP40 Multipole Versions)

Dimensions in mm  
Projection/First angle

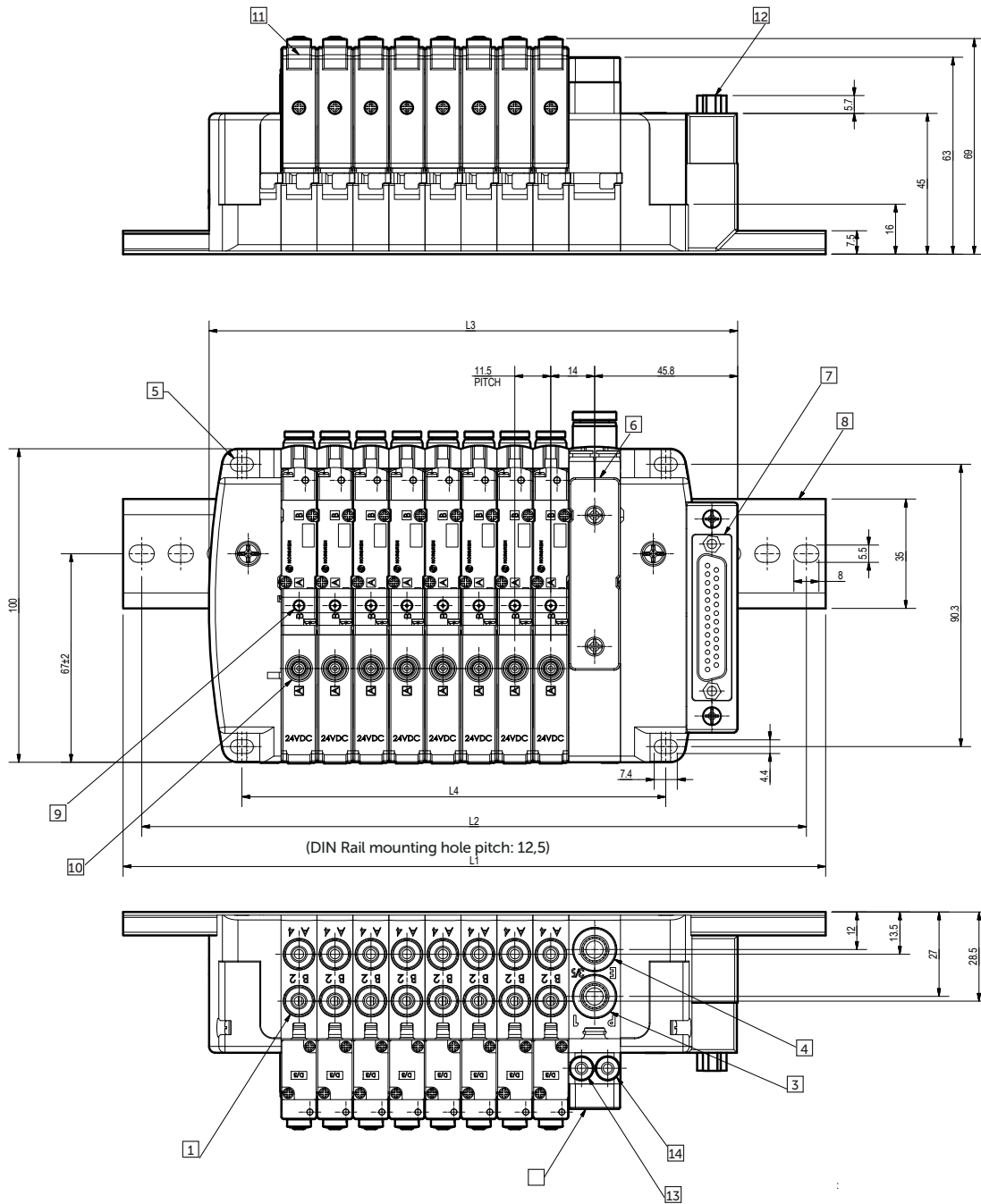

- 1 Outlet Port: PIF for tube O.D 4, O.D 6, O.D 5/32", O.D 1/4"
- 2 Sup/exh module
- 3 Supply Port: PIF for tube O.D 8, O.D 5/16"
- 4 Exhaust Port: PIF for tube O.D 8, O.D 5/16"
- 5 Mounting 4x M4
- 6 Exhaust Port: Blank Plate
- 7 Applicable connector: D-Sub Connector 25 Pin
- 8 DIN Rail
- 9 Manual override (Port 2)
- 10 Manual override (Port 4)
- 11 LED
- 12 Connector direction: vertical or horizontal
- 13 Supply Port of external pilot: PIF for tube O.D. 4, O.D. 5/32
- 14 Exhaust Port of external pilot: PIF for tube O.D. 4, O.D. 5/32"

N:	2	3	4	5	6	7	8	9	10	11	12	13	14	15	16	17	18	19	20	21	22	23	24
Stations																							
L1 (mm)			200				250					300					387.5				437.5		
L2 (mm)			187.5				237.5					287.5					375				425		
L3 (mm)	100	111.5	123	134.5	146	157.5	169	180.5	192	220	231.5	243	254.5	266	277.5	289	300.5	312	323.5	335	346.5	358	369.5
L4 (mm)	66.5	78	89.5	101	112.5	124	135.5	147	158.5	186.5	198	209.5	221	232.5	244	255.5	267	278.5	290	301.5	313	324.5	336

\*2~10 stations: one Sup/Exh Module is required. 11~24 stations: two Sup/Exh Modules are recommended.

# VR10 Series (Valve Island) External Pilot with Silencer (IP40 Multipole Versions)

Dimensions in mm  
Projection/First angle

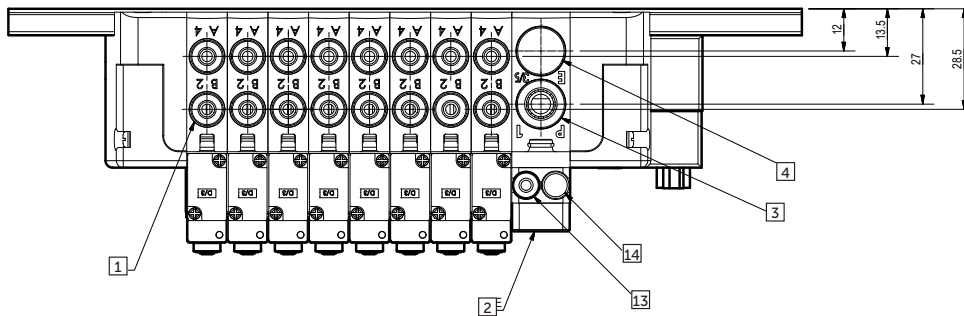
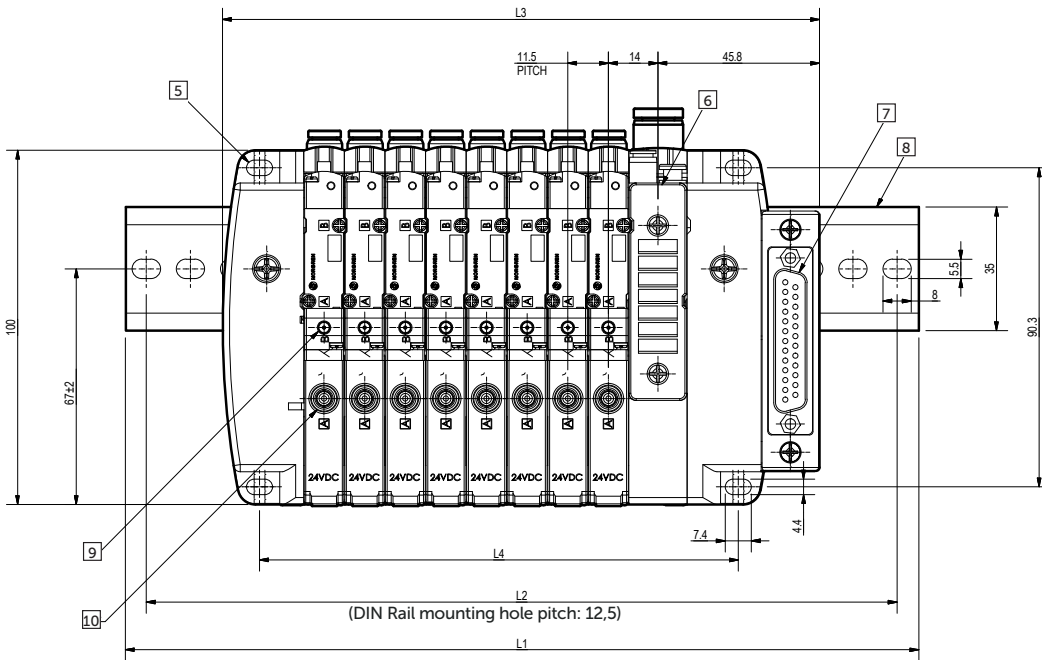
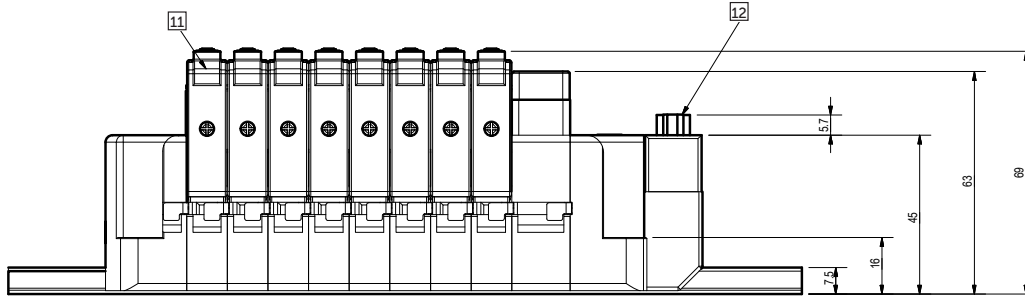

- 1 Outlet Port: PIF for tube O.D 4, O.D 6, O.D 5/32", O.D 1/4"
- 2 Sup/exh module
- 3 Supply Port: PIF for tube O.D 8, O.D 5/16"
- 4 Plug
- 5 Mounting 4x M4
- 6 Exhaust Port: Silencer Plate
- 7 Applicable connector: D-Sub Connector 25 Pin
- 8 DIN Rail
- 9 Manual override (Port 2)
- 10 Manual override (Port 4)
- 11 LED
- 12 Connector direction: vertical or horizontal
- 13 Supply Port of external pilot: PIF for tube O.D. 4, O.D. 5/32"
- 14 Plug

N: Stations	2	3	4	5	6	7	8	9	10	11	12	13	14	15	16	17	18	19	20	21	22	23	24
L1 (mm)			200				250					300					387.5			437.5			
L2 (mm)			187.5				237.5					287.5					375			425			
L3 (mm)	100	111.5	123	134.5	146	157.5	169	180.5	192	220	231.5	243	254.5	266	277.5	289	300.5	312	323.5	335	346.5	358	369.5
L4 (mm)	66.5	78	89.5	101	112.5	124	135.5	147	158.5	186.5	198	209.5	221	232.5	244	255.5	267	278.5	290	301.5	313	324.5	336

\*2~10 stations: one Sup/Exh Module is required. 11~24 stations: two Sup/Exh Modules are recommended.

# VR15 Series (Valve Island) Internal Pilot without Silencer (IP40 Multipole Versions)

Dimensions in mm  
Projection/First angle

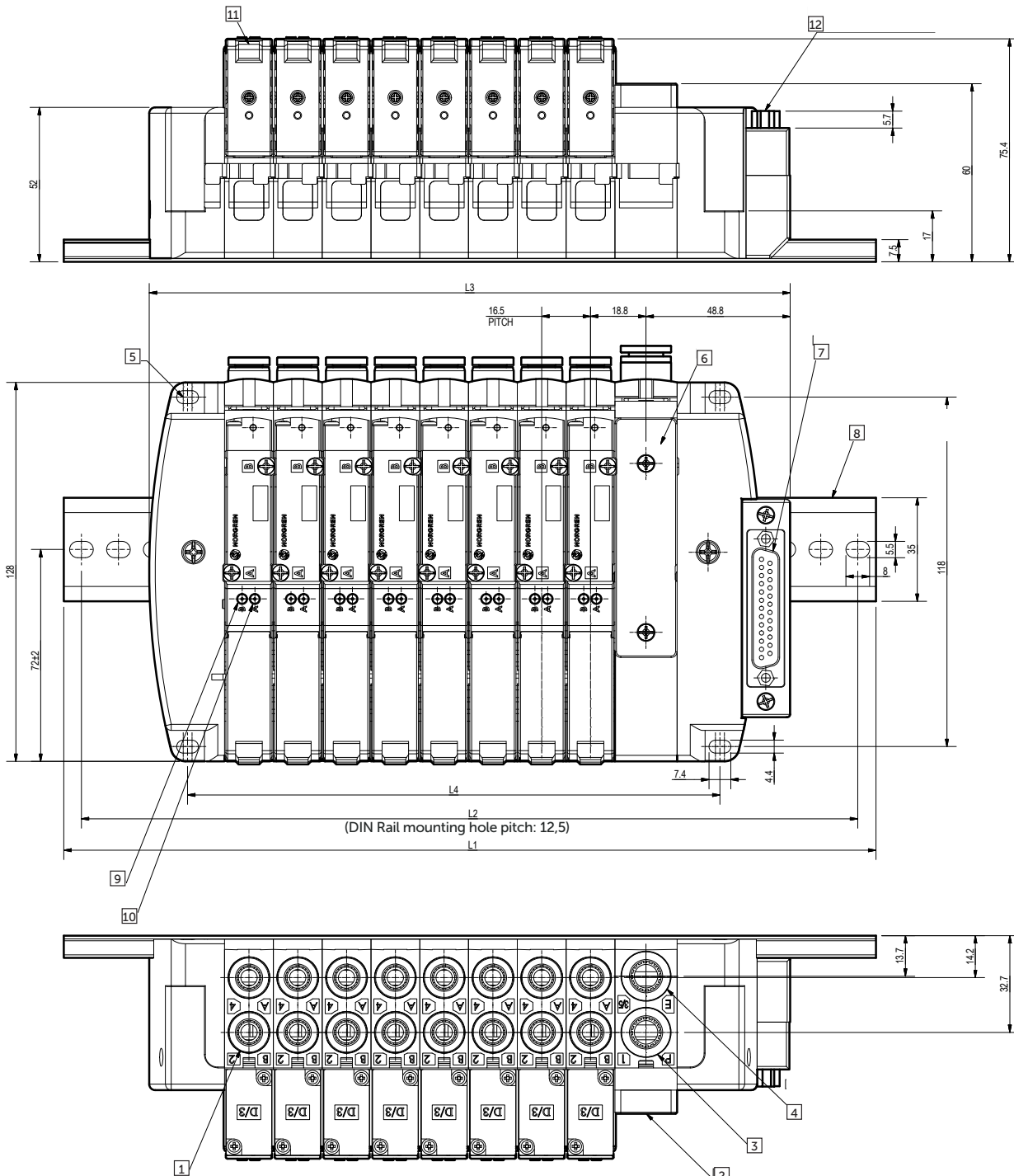

- 1 Outlet Port: PIF for tube O.D. 4, O.D 6, O.D 8, O.D 1/4", O.D 5/16"
- 2 Sup/exh module
- 3 Supply Port: PIF for tube O.D 10, O.D 3/8"
- 4 Exhaust Port: PIF for tube O.D 10, O.D 3/8"
- 5 Mounting 4x M4
- 6 Exhaust Port: Blank Plate

- 7 Applicable connector: D-Sub Connector 25 Pin
- 8 DIN Rail
- 9 Manual override (Port 2)
- 10 Manual override (Port 4)
- 11 LED
- 12 Connector direction: vertical or horizontal

N: Stations	2	3	4	5	6	7	8	9	10	11	12	13	14	15	16	17	18	19	20	21	22	23	24
L1 (mm)			250					300				400					500					587	
L2 (mm)			237.5					287.5				387.5					487.5					574.5	
L3 (mm)	117.7	134.2	150.7	167.2	183.7	200.2	216.7	233.2	249.7	287.2	303.7	320.2	336.7	353.2	369.7	386.2	402.7	419.2	435.7	452.2	468.7	485.2	501.7
L4 (mm)	81	97.5	114	130.5	147	163.5	180	196.5	213	250.5	267	283.5	300	316.5	333	349.5	366	382.5	399	415.5	432	448.5	465

\*2~10 stations: one Sup/Exh Module is required. 11~24 stations: two Sup/Exh Modules are recommended.

### VR15 Series (Valve Island) Internal Pilot with Silencer (IP40 Multipole Versions)

Dimensions in mm  
Projection/First angle

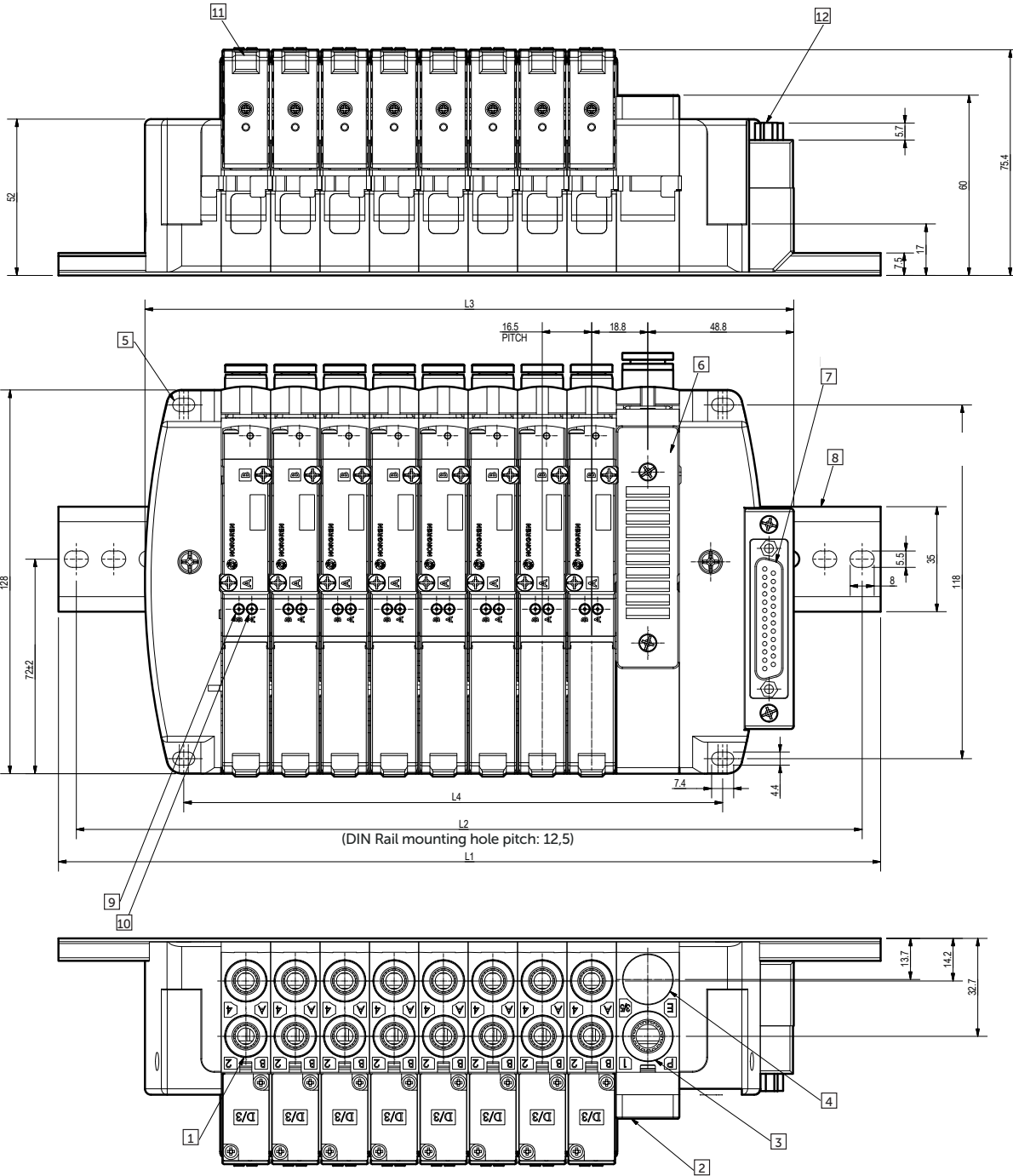

- 1 Outlet Port: PIF for tube O.D. 4, O.D 6, O.D 8, O.D 1/4", O.D 5/16"
- 2 Sup/exh module
- 3 Supply Port: PIF for tube O.D 10, O.D 3/8"
- 4 Plug
- 5 Mounting 4x M4
- 6 Exhaust Port: Silencer Plate

- 7 Applicable connector: D-Sub Connector 25 Pin
- 8 DIN rail
- 9 Manual override (Port 2)
- 10 Manual override (Port 4)
- 11 LED
- 12 Connector direction: vertical or horizontal

N:	2	3	4	5	6	7	8	9	10	11	12	13	14	15	16	17	18	19	20	21	22	23	24
L1 (mm)			250					300					400						500				587
L2 (mm)			237.5					287.5					387.5						487.5				574.5
L3 (mm)	117.7	134.2	150.7	167.2	183.7	200.2	216.7	233.2	249.7	287.2	303.7	320.2	336.7	353.2	369.7	386.2	402.7	419.2	435.7	452.2	468.7	485.2	501.7
L4 (mm)	81	97.5	114	130.5	147	163.5	180	196.5	213	250.5	267	283.5	300	316.5	333	349.5	366	382.5	399	415.5	432	448.5	465

\*2~10 stations: one Sup/Exh Module is required. 11~24 stations: two Sup/Exh Modules are recommended.

## VR15 Series (Valve Island) External Pilot without Silencer (IP40 Multipole Versions)

Dimensions in mm  
Projection/First angle

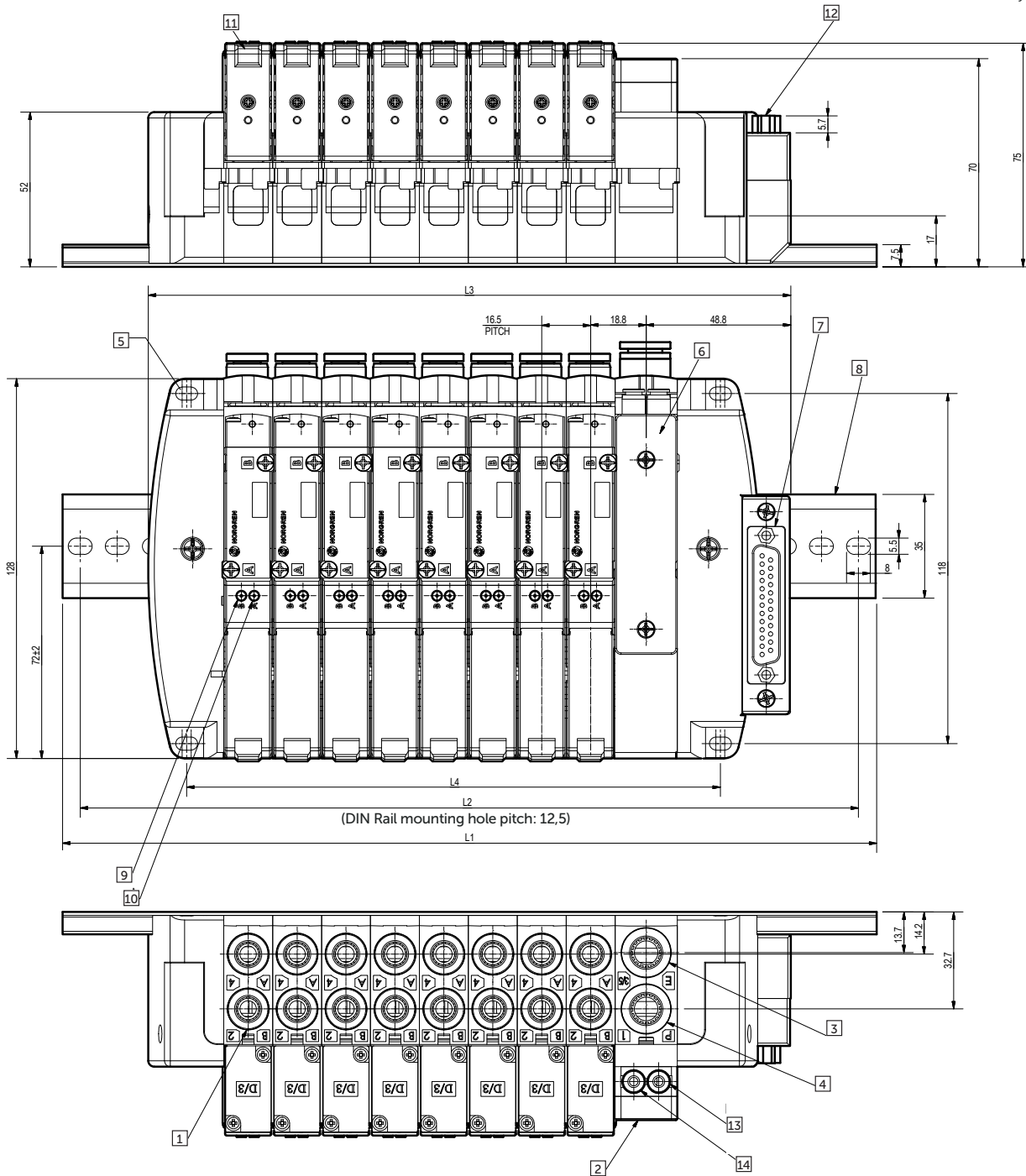

- 1 Outlet Port: PIF for tube O.D. 4, O.D 6, O.D 8, O.D 1/4", O.D 5/16"
- 2 Sup/exh module
- 3 Exhaust Port: PIF for tube O.D 10, O.D 3/8"
- 4 Supply Port: PIF for tube O.D 10, O.D 3/8"
- 5 Mounting 4x M4
- 6 Exhaust Port: Blank Plate
- 7 Applicable connector: D-Sub Connector 25 Pin

- 8 DIN Rail
- 9 Manual override (Port 2)
- 10 Manual override (Port 4)
- 11 LED
- 12 Connector direction: vertical or horizontal
- 13 Exhaust Port of external pilot: PIF for tube O.D. 4, O.D. 5/32
- 14 Supply Port of external pilot: PIF for tube O.D. 4, O.D. 5/32"

N: Stations	2	3	4	5	6	7	8	9	10	11	12	13	14	15	16	17	18	19	20	21	22	23	24
L1 (mm)	250				300				400				500				587						
L2 (mm)	237.5				287.5				387.5				487.5				574.5						
L3 (mm)	117.7	134.2	150.7	167.2	183.7	200.2	216.7	233.2	249.7	287.2	303.7	320.2	336.7	353.2	369.7	386.2	402.7	419.2	435.7	452.2	468.7	485.2	501.7
L4 (mm)	81	97.5	114	130.5	147	163.5	180	196.5	213	250.5	267	283.5	300	316.5	333	349.5	366	382.5	399	415.5	432	448.5	465

\*2~10 stations: one Sup/Exh Module is required. 11~24 stations: two Sup/Exh Modules are recommended.

# VR15 Series (Valve Island) External Pilot with Silencer (IP40 Multipole Versions)

Dimensions in mm  
Projection/First angle

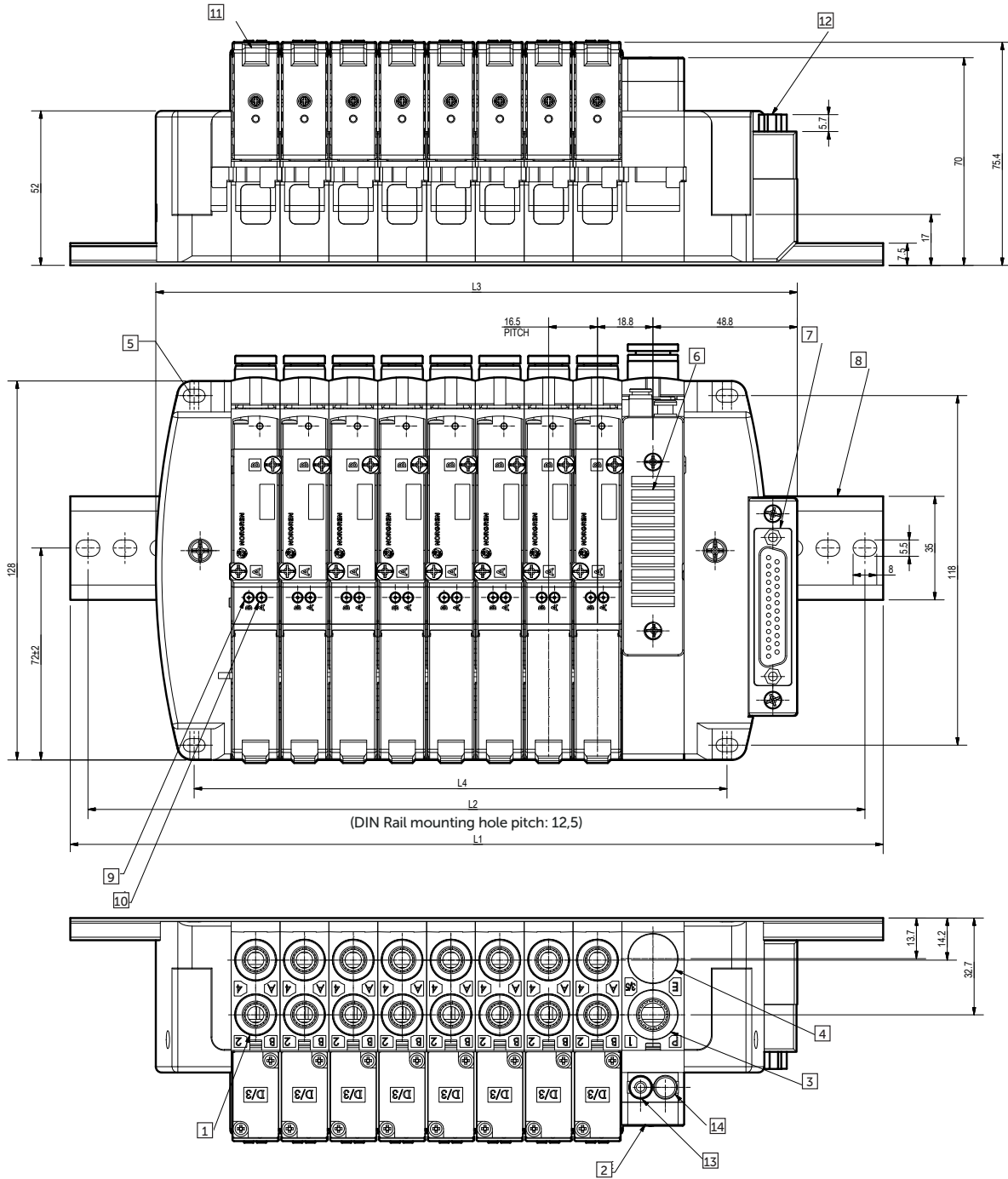

- 1 Outlet Port: PIF for tube O.D. 4, O.D 6, O.D 8, O.D 1/4", O.D 5/16"
- 2 Sup/exh module
- 3 Supply Port: PIF for tube O.D 10, O.D 3/8"
- 4 Plug
- 5 Mounting 4x M4
- 6 Exhaust Port: Silencer Plate
- 7 Applicable connector: D-Sub Connector 25 Pin
- 8 DIN Rail
- 9 Manual override (Port 2)
- 10 Manual override (Port 4)
- 11 LED
- 12 Connector direction: vertical or horizontal
- 13 Supply Port of external pilot: PIF for tube O.D. 4, O.D. 5/32
- 14 Plug

N:	2	3	4	5	6	7	8	9	10	11	12	13	14	15	16	17	18	19	20	21	22	23	24
Stations																							
L1 (mm)			250					300					400					500					587
L2 (mm)			237.5					287.5					387.5					487.5					574.5
L3 (mm)	117.7	134.2	150.7	167.2	183.7	200.2	216.7	233.2	249.7	287.2	303.7	320.2	336.7	353.2	369.7	386.2	402.7	419.2	435.7	452.2	468.7	485.2	501.7
L4 (mm)	81	97.5	114	130.5	147	163.5	180	196.5	213	250.5	267	283.5	300	316.5	333	349.5	366	382.5	399	415.5	432	448.5	465

\*2~10 stations: one Sup/Exh Module is required. 11~24 stations: two Sup/Exh Modules are recommended.

## Warning

These products are intended for use in industrial compressed air systems only. Do not use these products where pressures and temperatures can exceed those listed under **»Technical features/ data«**.

Before using these products with fluids other than those specified, for non-industrial applications, life-support systems or other applications not within published specifications, consult Norgren.

Through misuse, age, or malfunction, components used in fluid power systems can fail in various modes.

The system designer is warned to consider the failure modes of all component parts used in fluid power systems and to provide adequate safeguards to prevent personal injury or damage to equipment in the event of such failure.

System designers must provide a warning to end users in the system instructional manual if protection against a failure mode cannot be adequately provided.

System designers and end users are cautioned to review specific warnings found in instruction sheets packed and shipped with these products.